

Toma de Fuerza Power Take Off's

código code

065803

28030, 28035, 28042, 28046

Iveco

Posterior Neumático

Rear Pneumatic



Descripción Description

Toma de fuerza de un piñón, para montar bombas ISO 4 taladros. Accionamiento neumático, para montar en el registro posterior de 4 taladros de la caja de cambios.

Power Take-off one gear, to connect ISO 4 bolts pumps. Pneumatic shifting, mounting on rear 4 bolts-window of the Gearbox.

Datos Principales Main Data

Par nominal Torque (Nm)	Continuo Continuous	300
	Intermitente Intermittent	420
Potencia (Cv) a 1000 r.p.m. Power (HP) 1000 r.p.m	42 C.V // 32 Kw	
Lado de montaje Mounting position	Posterior Rear	
Sentido de giro de la bomba Pump rotation	Izquierdo Left Hand	
Peso Weight (Kg)	9	
Relación motor - Toma de Fuerza Engine to PTO ratio	28030	1: 0,460
	28035	1: 0,419
	28042	1: 0,538
	28046	1: 0,460

Códigos y Combinaciones Codes and Combinations

Tipos de salida Output types	Eje Shaft	Plato Flange	Bomba Pump
ISO 4 Taladros ISO 4 Bolts	065801	065802	065803
UNI 3 Taladros UNI 3 Bolts			065830

Toma de Fuerza Power Take Off's

código code

065803

28030, 28035, 28042, 28046

Iveco

Posterior Neumático
Rear Pneumatic

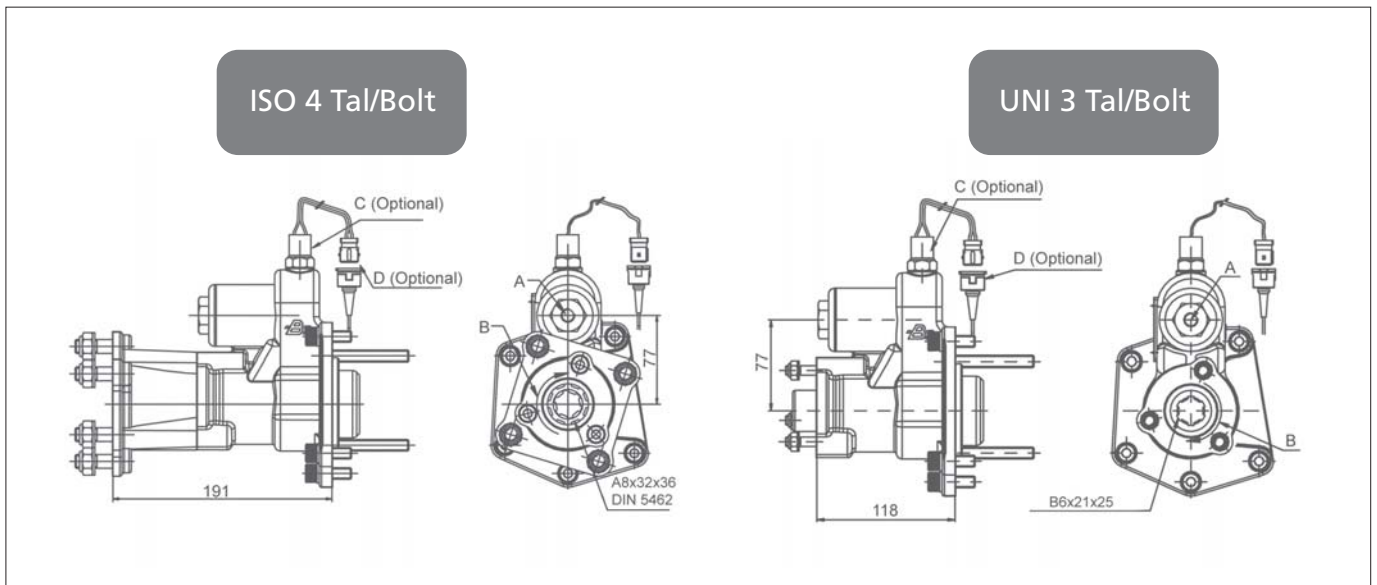

Notas Notes

A	Toma de aire, rosca 1/4" GAS	A	Air connection, thread 1/4" BSP
B	Sentido de giro	B	Rotation
C	Interruptor de contacto (100070015)	C	Passing contact switch. P/N 100070015
D	Conector con 3m de cable (906599)	D	Connector with 3m. of cable P/N 906599

Tipos de Salida Output Types

