

código code

0718803

G3/36 , /40, /45, /50,
/55, /60, /61

Mercedes

Posterior Neumático

Rear Pneumatic

Descripción Description



Toma de fuerza de un piñón para montar bombas ISO 4 taladros. Accionamiento interno neumático. Montaje sobre el registro posterior de 5 taladros de la caja de cambios.

Power Take-off one gear to connect ISO 4 bolts pumps. Pneumatic shifting. Mounting on rear 5 bolts-window of the Gearbox.

Datos Principales Main Data

Par nominal Torque (Nm)	Continuo Continuous	500
	Intermitente Intermittent	700
Potencia (Cv) a 1000 r.p.m. Power (HP) 1000 r.p.m	70 C.V // 52 Kw	
Lado de montaje Mounting position	Posterior Rear	
Sentido de giro de la bomba Pump rotation	Izquierdo Left Hand	
Peso Weight (Kg)	6	
Relación motor - Toma de Fuerza Engine to PTO ratio	G3 36-5/8.98	1: 0,394
	G3 40-5/7.508	1: 0,472
	G3 45-6/8.5	1: 0,460
	G3 50-5/8.5	1: 0,420
	G3 55-6/8.5	1: 0,460
	G3 60-5/5.4	1: 0,652
	G3 60-5/6.106	1: 0,581
	G3 60-5/7.5	1: 0,472
G3 61-5/6.1	1: 0,578	

Códigos y Combinaciones Codes and Combinations

Tipos de salida Output types	Eje Shaft	Plato Flange	Bomba Pump (DIN 5462)
Accionamiento neumático Pneumatic shifting		0718802	0718803

código code

0718803

G3/36 , /40, /45, /50,
/55, /60, /61

Mercedes

Posterior Neumático

Rear Pneumatic

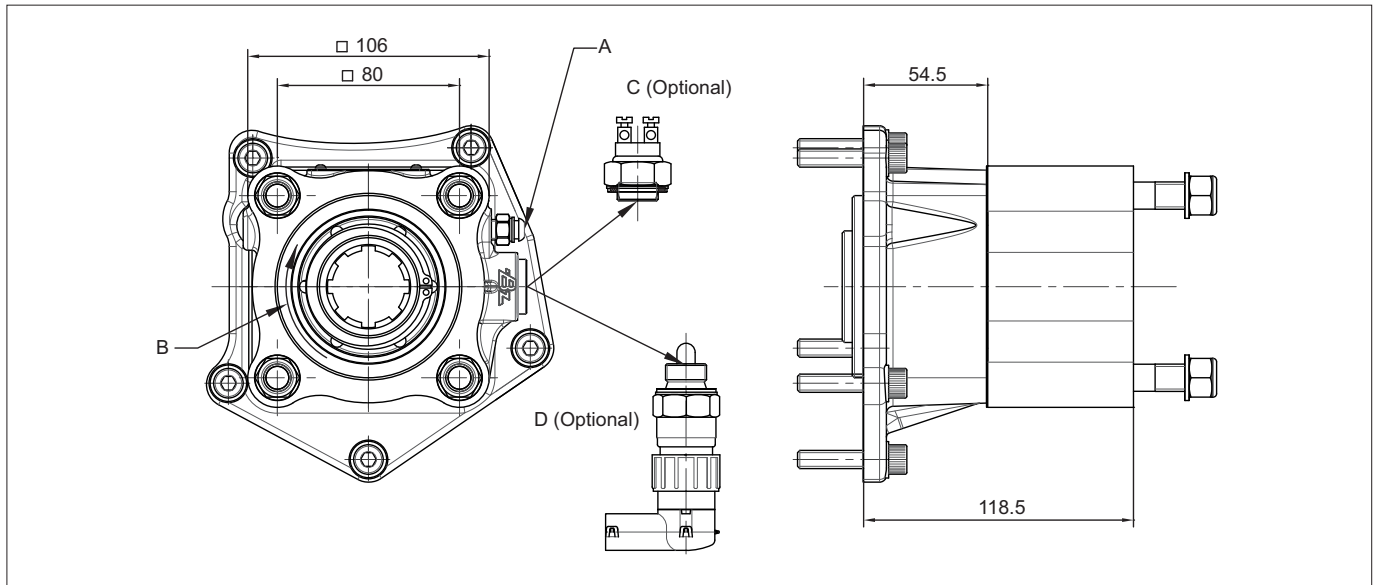

Notas Notes

A	Toma de aire, rosca 1/8" GAS	A	Air connection, thread 1/8" BSP
B	Sentido de giro	B	Rotation
C	Interruptor neumático. (100070018)	C	Pressure switch. P/N 100070018
D	Interruptor de contacto. (9024999)	D	Passing contact switch. P/N 9024999

Tipos de Salida Output Types

FLANGE TYPE		CODE
SAE:	1100	7015504
	1300	
	1400	7015604
DIN:	90	7015804
	100	7015704

Adaptador Plato / Flange Adapter