

Toma de Fuerza Power Take Off's

código code

0717703

G131, G211
G210, G221, G231, G240
G260, G280, G281, G330
Casquillo cierre bomba / Closed pump cover

Mercedes

Posterior Neumático

Rear Pneumatic



Descripción Description

Toma de fuerza reforzada de dos piñones, relación con salida de plato para conectar a una transmisión. Accionamiento neumático. Montaje sobre el registro posterior de 7 taladros de la caja de cambios. Indicador de funcionamiento opcional.

Heavy Duty Power Take-off two gears, ratio with flange output ready to connect a transmission. Pneumatic shifting. Mounting on rear 7 bolts-window of the Gearbox. Optional: Passing contact switch.

Datos Principales Main Data

Relación Interna Internal Ratio		1:1,04		1:1,26		
Par nominal Torque (Nm)	Continuo Continuous		600		500	
	Intermitente Intermittent		800		700	
Potencia (Cv) a 1000 r.p.m. Power (HP) 1000 r.p.m			85 C.V // 64 Kw		70 C.V // 53 Kw	
Lado de montaje Mounting position			Posterior Rear			
Sentido de giro de la bomba Pump rotation			Derecho Right Hand			
Peso Weight (Kg)			19,5			
Relación motor Toma de Fuerza Engine to PTO ratio	G131		1: 0,767		1: 0,929	
	G210	Larga High	1: 1,071		1: 1,297	
		Normal Normal	1: 0,884		1: 1,071	
	G211	Larga High	1: 0,884		1: 1,071	
		Normal Normal	1: 0,738		1: 0,894	
	G221		1: 0,770		1: 0,932	
	G231	Larga High	1: 0,884		1: 1,071	
		Normal Normal	1: 0,738		1: 0,894	
	G240	Larga High	1: 1,290		1: 1,562	
		Normal Normal	1: 1,071		1: 1,297	
	G260	Larga High	1: 1,560		1: 1,890	
		Normal Normal	1: 1,290		1: 1,562	
	G280	Larga High	1: 1,290		1: 1,562	
		Normal Normal	1: 1,071		1: 1,297	
G281	Larga High	1: 1,331		1: 1,612		
	Normal Normal	1: 1,040		1: 1,260		
G330	Larga High	1: 1,373		1: 1,663		
	Normal Normal	1: 1,071		1: 1,297		
Códigos Codes	G210, G221, G231 G240, G260, G280 G281, G330	Bomba Pump (DIN 5462)	Sin Retarder Without Retarder	0717703		
		Plato Flange	Con Retarder With Retarder	0718003		
	G131, G211	Bomba Pump (DIN 5462)	Sin Retarder Without Retarder	0717702		
			Con Retarder With Retarder	0718002		
		Plato Flange	Sin Retarder Without Retarder	0721403		
			Con Retarder With Retarder	0721003		
G131, G211	Plato Flange	Sin Retarder Without Retarder	0721402			
		Con Retarder With Retarder	0721002			



Toma de Fuerza Power Take Off's

código code

0717703

G131, G211
G210, G221, G231, G240
G260, G280, G281, G330
Casquillo cierre bomba / Closed pump cover

Mercedes

Posterior Neumático
Rear Pneumatic

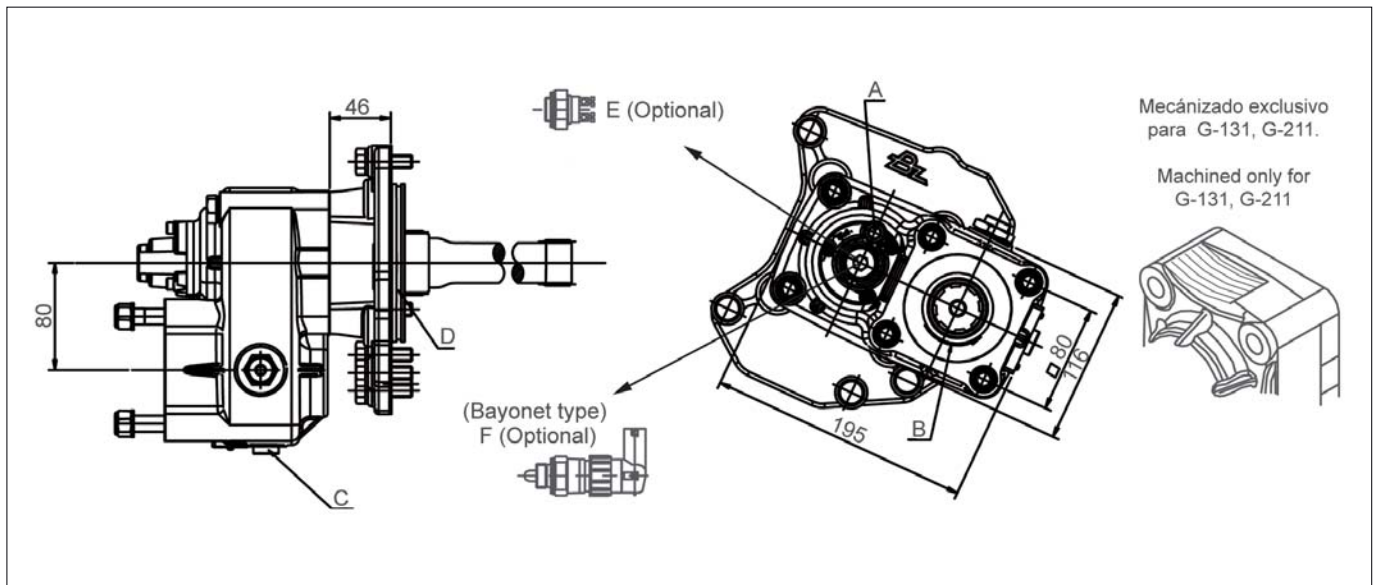

Notas Notes

Trabajo continuo - altas revoluciones puede requerir enfriador aceite externo		On continuous works & high speed an external oil cooler could be required	
A	Toma de aire, rosca 1/8" GAS	A	Air connection, thread 1/8" BSP
B	Sentido de giro	B	Rotation
C	Tapón de drenaje del aceite	C	Oil drain plug
D	Casquillo cierre bomba de engrase	D	Closed lubrication pump cover
E	Interruptor neumático. (100070018)	E	Pressure switch. P/N 100070018
F	Interruptor de contacto. (9024999)	F	Passing contact switch. P/N 9024999

Tipos de Salida Output Types

