

código code

**07218K03**

G131, G210, G211, G221, G231  
G240, G260, G280, G281, G330  
Casquillo cierre bomba / Closed pump cover

# Mercedes

Posterior Neumático (1: 1,30)  
Rear Pneumatic



## Descripción Description

Kit toma de fuerza reforzada + brida (sin eje), relación 1:1,30 para montar bombas ISO 4 taladros. Accionamiento neumático. Montaje sobre el registro posterior de 8 taladros de la caja de cambios. Indicador de funcionamiento y/o eje adaptador opcional.

Base PTO + flange kit (without shaft), heavy duty 1:1,30 to connect ISO 4 bolts pumps. Pneumatic shifting. Mounting on rear 8 bolts-window of the Gearbox. Optional: Passing contact switch and adapter shaft.

## Datos Principales Main Data

Par máximo Max. Torque (Nm)	Continuo Continuous		400
	Intermitente Intermittent		570
Potencia (Cv) a 1000 r.p.m. Power (HP) 1000 r.p.m			57 C.V // 43 Kw
Lado de montaje Mounting position			Posterior Rear
Sentido de giro de la bomba Pump rotation			Derecho Clockwise
Peso Weight (Kg)			18
Relación motor - Toma de Fuerza Engine to PTO ratio	G131		1: 0,96
	G210	1: 1,339	Larga High
		1: 1,105	Normal Normal
	G211	1: 1,105	Larga High
		1: 0,923	Normal Normal
	G221		1: 1,001
	G231	1: 1,105	Larga High
		1: 0,924	Normal Normal
	G240	1: 1,612	Larga High
		1: 1,339	Normal Normal
	G260	1: 1,950	Larga High
		1: 1,612	Normal Normal
	G280	1: 1,612	Larga High
1: 1,339		Normal Normal	
G281	1: 1,339	Larga High	
	1: 1,053	Normal Normal	
G230, G330	1: 1,742	Larga High	
	1: 1,360	Normal Normal	

## Códigos y Combinaciones Codes and Combinations

Kit toma de fuerza Base con brida Base PTO kit with flange		+	Kit de eje adaptador Adapter shaft kit	
Salida Plato Flange Output	07218K02	G240, Z=16. L=252mm		700904
		G240, Retarder. Z= 16. L=277mm		703704
Salida bomba Pump Output	DIN 5462 07218K03	G281 IT, Z=16. L=293mm (Aquatarder)		7018104
		G281-12 Z=16. L=268mm		7018304

código code

**07218K03**

G131, G210, G211, G221, G231  
G240, G260, G280, G281, G330  
Casquillo cierre bomba / Closed pump cover

# Mercedes

Posterior Neumático (1:1,30)  
Rear Pneumatic

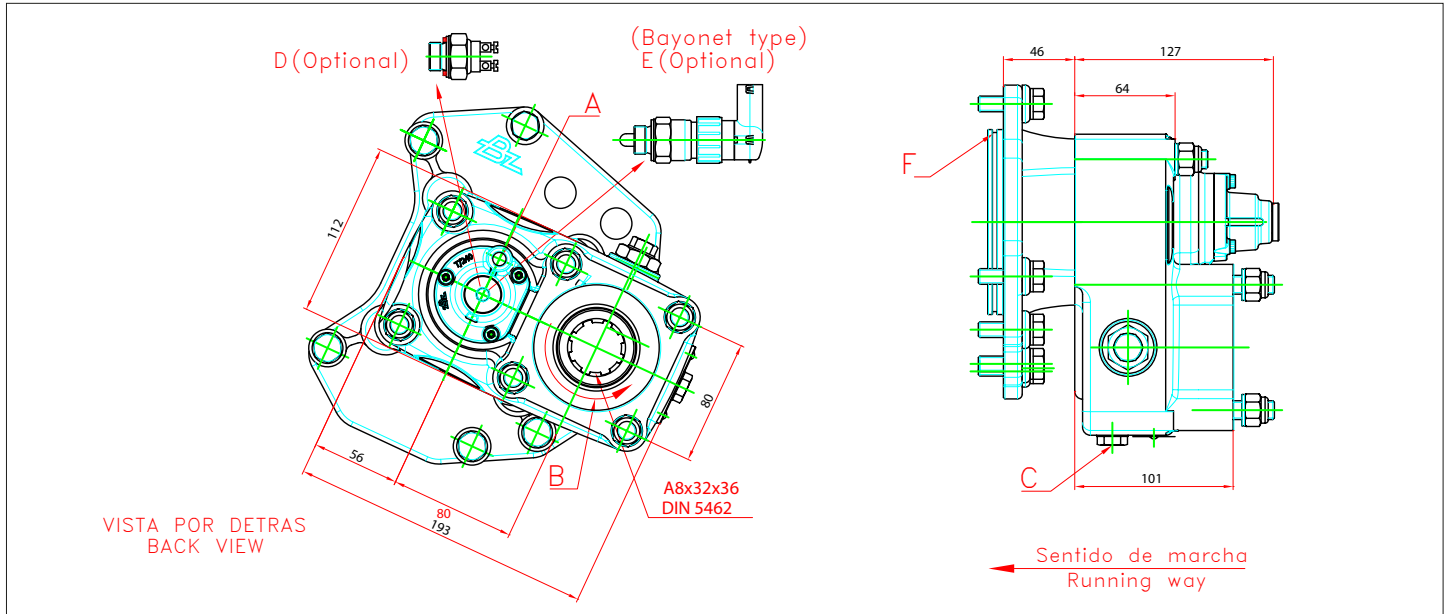

## Notas Notes

A	Toma de aire, rosca 1/8" GAS	A	Air connection, thread 1/8" BSP
B	Sentido de giro	B	Rotation
C	Tapón de drenaje del aceite	C	Oil drain plug
D	Interruptor neumático (100070018)	D	Pressure switch. P/N 100070018
E	Interruptor de contacto.( 9024999)	E	Passing contact switch. P/N 9024999
F	Casquillo cierre bomba de engrase	F	Closed lubrication pump cover

## Tipos de Salida Output Types

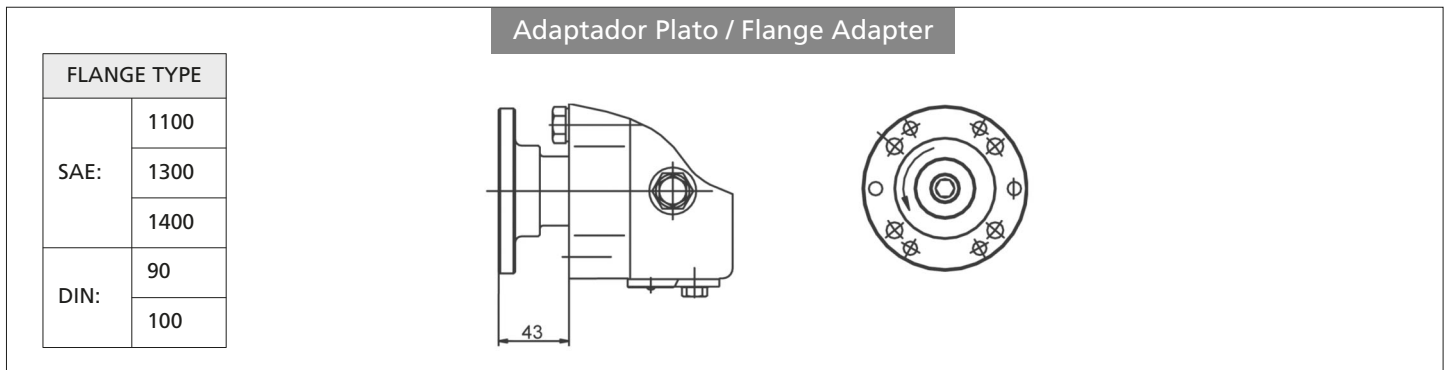

FLANGE TYPE	
SAE:	1100
	1300
	1400
DIN:	90
	100