

código code

**075303**G28, G32, G33  
NSG370-6, NSG400-6

# Mercedes

Posterior  
Rear

## Descripción Description

Toma de fuerza directo, para montar bombas ISO 4 taladros. Para montar en el registro posterior de 4 taladros de la caja de cambios.

Direct Power Take-off, to connect ISO 4 bolts pumps. Mounting on rear 4 holes-window of the Gearbox.

### Datos Principales Main Data

Par nominal Torque (Nm)	Continuo Continuous	140
	Intermitente Intermittent	190
Potencia (Cv) a 1000 r.p.m. Power (HP) 1000 r.p.m		20 C.V // 15 Kw
Lado de montaje Mounting position		Posterior Rear
Sentido de giro de la bomba Pump rotation	G28, G32, G33	Derecho Right Hand
	NSG370-6, NSG400-6	Izquierdo Left-Hand
Peso Weight (Kg)		2.3
Relación motor - Toma de Fuerza Engine to PTO ratio		1: 0,9

### Códigos y Combinaciones Codes and Combinations

Caja de cambios Gearbox	G28, G32, G33	NSG370-6, NSG400-6
Rodamiento de Bolas Ball Bearing	075203	0717503
Rodamiento Conico Taper Roller Bearing	075303	0717403

código code

075303

G28, G32, G33  
NSG370-6, NSG400-6

# Mercedes

Posterior  
Rear

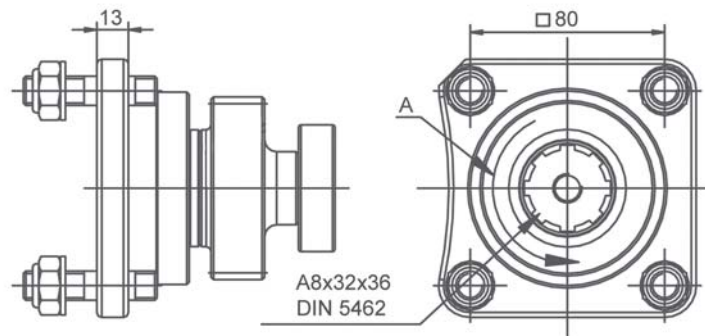

Rod. Bolas Ball Bearings

### Notas Notes

A	Sentido de giro	A	Pump Rotation
---	-----------------	---	---------------

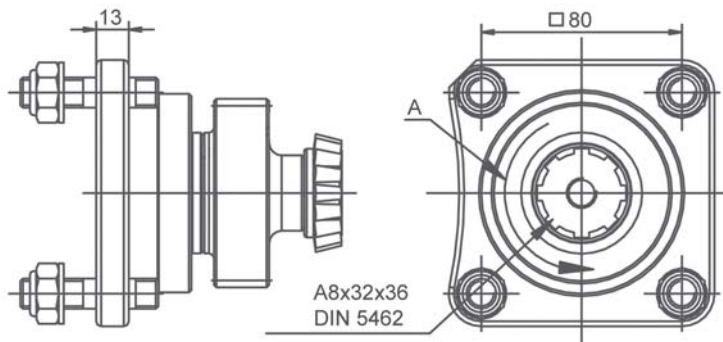

Rod. Conicos Taper Roller Bearings