

Toma de Fuerza Power Take Off's

código code

1010603

S5-50, S5-90, S6-65, S6-66, S6-70S6-75, S6-80, S6-90
6S-800TO (Volvo ZTO 1006), 6S-1000TO, 6S-1200TD/TO

ZF

Posterior Neumático

Rear Pneumatic

Descripción Description



Toma de fuerza de tres piñones relaciones internas varias, para montar bombas ISO 4 taladros. Accionamiento neumático, montaje sobre el registro frontal de 4 taladros de la caja de cambios.

Power Take-off three gears several internal ratios, to connect Iso 4 bolts pumps. Pneumatic shifting, mounting on rear 4 bolts-window of the Gearbox.

Datos Principales Main Data

Par nominal Torque (Nm)	Continuo Continuous	300
	Intermitente Intermittent	420
Potencia (Cv) a 1000 r.p.m. Power (HP) 1000 r.p.m	42 C.V // 32 Kw	
Lado de montaje Mounting position	Posterior Rear	
Sentido de giro de la bomba Pump rotation	Izquierdo Left Hand	
Peso Weight (Kg)	19	
Relación motor - Toma de Fuerza Engine to PTO ratio	ANEXO ATTACHED	

Relación Interna Internal Ratio		1:1,4	1:1,65	1:2
Códigos Codes	Bomba Pump (DIN 5462)	1012603	1013203	1010603
	Plato Flange	1012502	1013102	1010702

Toma de Fuerza Power Take Off's

código code

1010603

S5-50, S5-90, S6-65, S6-66, S6-70S6-75, S6-80, S6-90
6S-800TO (Volvo ZTO 1006), 6S-1000TO, 6S-1200TD/TO

ZF

Posterior Neumático

Rear Pneumatic

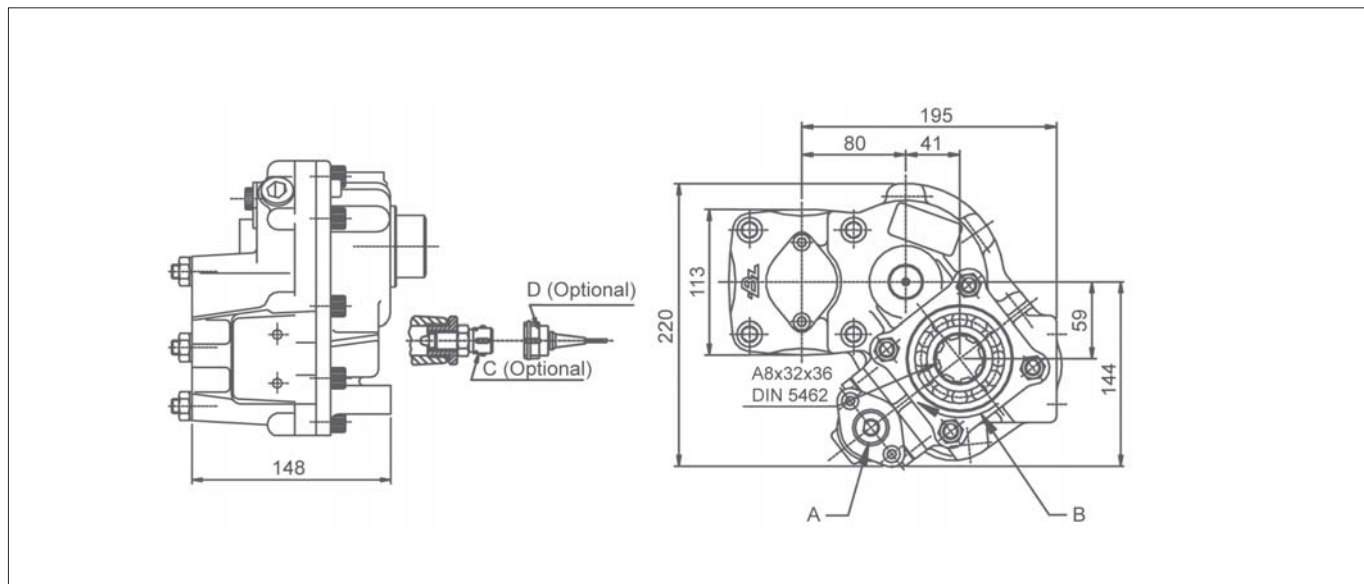

Notas Notes

Kit Lubricación Opcional 900199		Lubrication Kit Optional 900199	
A	Toma de aire, rosca M12 - 1.5	A	Air connection, thread M12 - 1.5
B	Sentido de giro	B	Rotation
C	Indicador de funcionamiento. (100070001)	C	Passing contact switch. P/N 100070001
D	Conector con 3m de cable (906599)	D	Connector with 3m. of cable P/N 906599

Tipos de Salida Output Types

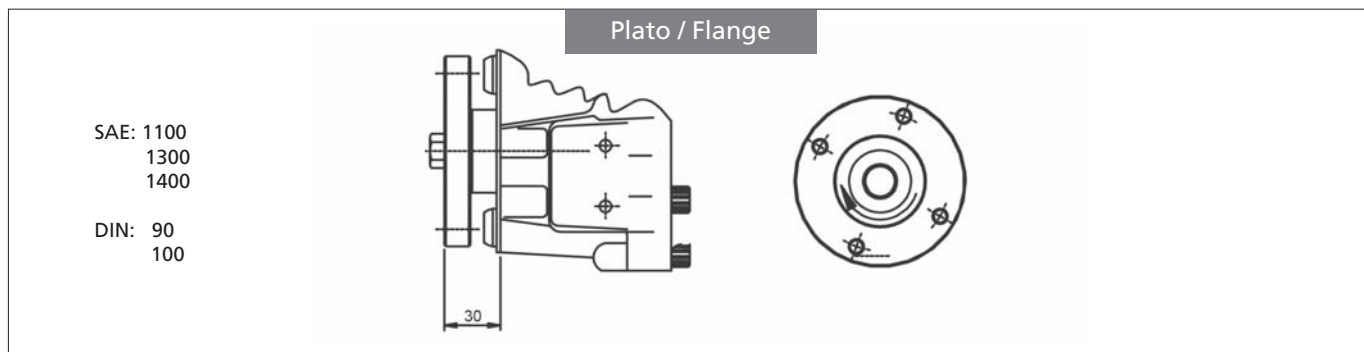

SAE: 1100
1300
1400

DIN: 90
100

BZ
bezares s.a.

Av. de las Retamas. Parcela:145. 45950. Casarrubios del Monte. Toledo (Spain) Tlf: +34 902 333 331
www.bezares.com bezares@bezares.com

24.13.11

Toma de Fuerza Power Take Off's

código code

1010603

S5-50, S5-90, S6-65, S6-66, S6-70S6-75, S6-80, S6-90
6S-800TO (Volvo ZTO 1006), 6S-1000TO, 6S-1200TD/TO

ZF

Posterior Neumático

Rear Pneumatic

CAJA GEARBOX	RELACIÓN RATIO				
		1:1,4	1:1,65	1:2	
S5-50	/ 5.30	1: 0,914	1: 1,077	1: 1,306	
	/ 5.50	1: 0,861	1: 1,014	1: 1,230	
	/ 6.20	1: 0,763	1: 0,899	1: 1,090	
	/ 6.61	1: 0,714	1: 0,841	1: 1,020	
	/ 6.61+GV80 / 5.30	Larga High	1: 0,891	1: 1,051	1: 1,274
		Normal Normal	1: 0,714	1: 0,841	1: 1,020
	/ 8.02	1: 0,590	1: 0,696	1: 0,844	
	/ 8.02+GV80 / 6.20	Larga High	1: 0,899	1: 0,899	1: 1,090
Normal Normal		1: 0,589	1: 0,694	1: 0,842	
S5-90GP	/ GPA	1: 1,246	1: 1,468	1: 1,780	
S6-65	/ 6.37	1: 0,91	1: 1,072	1: 1,300	
	/ 6.70	1: 0,868	1: 1,023	1: 1,240	
	/ 7.0+GV70 / 7.67	Larga High	1: 0,638	1: 0,752	1: 0,912
		Normal Normal	1: 0,511	1: 0,602	1: 0,730
	/ 7.40	1: 0,786	1: 0,927	1: 1,124	
	/ 7.52	1: 0,777	1: 0,915	1: 1,110	
	/ 9.00	1: 0,646	1: 0,762	1: 0,924	
	/ 7.97+GV80 / 6.70	Larga High	1: 0,868	1: 1,023	1: 1,240
		Normal Normal	1: 0,735	1: 0,866	1: 1,050
	/ 9.00+GV80 / 6.70	Larga High	1: 0,868	1: 1,023	1: 1,240
		Normal Normal	1: 0,646	1: 0,762	1: 0,924
	/ 9.00+GV80 / 7.52	Larga High	1: 0,775	1: 0,914	1: 1,108
Normal Normal		1: 0,646	1: 0,762	1: 0,924	
S6-66	/ 7.36-1.0	1: 0,730	1: 0,861	1: 1,044	
	/ 9.06-1.0	1: 0,582	1: 0,686	1: 0,832	
S6-70	/ 6.8	1: 0,719	1: 0,848	1: 1,028	
	/ 6.8+GV70 / 5.71	Larga High	1: 0,856	1: 1,009	1: 1,244
		Normal Normal	1: 0,719	1: 0,848	1: 1,028
	/ 7.36	1: 0,669	1: 0,788	1: 0,956	
	/ 7.92	1: 0,617	1: 0,727	1: 0,882	
	/ 9.03	1: 0,541	1: 0,638	1: 0,774	
	/ 9.59	1: 0,511	1: 0,602	1: 0,730	
S6-75	/ 6.70+GV80 / 7.52	Normal Normal	1: 0,868	1: 1,023	1: 1,240
		Corta Low	1: 0,775	1: 0,914	1: 1,108
S6-80	/ 5.03	1: 1,092	1: 1,287	1: 1,560	
	/ 5.66	1: 1,036	1: 1,221	1: 1,480	

CAJA GEARBOX	RELACIÓN RATIO				
		1:1,4	1:1,65	1:2	
S6-80	/ 5.66+GV80 / 7.52	Larga High	1: 1,033	1: 1,217	1: 1,476
		Normal Normal	1: 0,778	1: 0,917	1: 1,112
	/ 6.10	1: 0,963	1: 1,135	1: 1,376	
	/ 6.7	1: 0,868	1: 1,023	1: 1,240	
	/ 6.7+GV80 / 5.30	Larga High	1: 1,101	1: 1,298	1: 1,574
		Normal Normal	1: 0,868	1: 1,023	1: 1,240
	/ 6.90	1: 0,721	1: 0,849	1: 1,030	
	/ 7.35	1: 0,772	1: 0,910	1: 1,104	
	/ 7.41	1: 0,788	1: 0,928	1: 1,126	
	/ 7.53	1: 0,777	1: 0,915	1: 1,110	
	/ 7.67	1: 0,756	1: 0,891	1: 1,080	
	/ 7.67+GV80 / 6.7	Larga High	1: 0,870	1: 1,026	1: 1,244
		Normal Normal	1: 0,760	1: 0,895	1: 1,086
	/ 7.90	1: 0,735	1: 0,866	1: 1,050	
	/ 9.00	1: 0,644	1: 0,759	1: 0,920	
	/ 9.00+GV80 / 5.30	Larga High	1: 1,101	1: 1,298	1: 1,574
		Normal Normal	1: 0,646	1: 0,762	1: 0,924
	/ 9.00+GV80 / 7.48	Larga High	1: 0,786	1: 0,927	1: 1,124
		Normal Normal	1: 0,646	1: 0,762	1: 0,924
	/ 9.00+GV80 / 7.52	Larga High	1: 0,775	1: 0,914	1: 1,124
Normal Normal		1: 0,646	1: 0,762	1: 0,924	
/ 5.67	1: 1,05	1: 1,237	1: 1,500		
/ 5.74	1: 1,036	1: 1,221	1: 1,480		
/ 6.37	1: 1,036	1: 1,221	1: 1,480		
/ 6.98	1: 0,856	1: 1,009	1: 1,224		
/ 7.03	1: 0,844	1: 0,994	1: 1,206		
/ 7.03+GV90 / 5.67	Larga High	1: 1,05	1: 1,237	1: 1,500	
	Normal Normal	1: 0,844	1: 0,994	1: 1,206	
/ 7.03+GV90 / 5.74	Larga High	1: 1,029	1: 1,212	1: 1,470	
	Normal Normal	1: 0,84	1: 0,99	1: 1,200	
/ 7.40	1: 0,805	1: 0,948	1: 1,150		
/ 9.01	1: 0,658	1: 0,775	1: 0,940		
/ 9.01+GV90 / 7.40	Larga High	1: 0,802	1: 0,945	1: 1,146	
	Normal Normal	1: 0,659	1: 0,777	1: 0,942	
6S800TO/6.58-0.78(Volvo ZTO 1006)	1: 0,742	1: 0,874	1: 1,060		
6S1000TO/6.75 - 0.78	1: 0,742	1: 0,874	1: 1,060		
6S1200TD/7.72 - 1.00	1: 0,756	1: 1,891	1: 1,080		
6S1200TO/6.75 - 0.83	1: 0,868	1: 1,240	1: 1,240		