

Toma de Fuerza Power Take Off's

código code

1022003

S5-50, S5-90, S6-65, S6-66, S6-70
S6-75, S6-80, S6-90, 6S-1000TO, 6S-1200TD/TO

ZF

Posterior Neumático

Rear Pneumatic



Descripción Description

Toma de fuerza reforzada de 2 piñones, para montar en el registro frontal de 4 taladros de la caja de cambios. Accionamiento neumático, para montar bombas Iso 4 taladros. Indicador de funcionamiento opcional.

Heavy Duty Power Take-off 2 gears, mounting on rear 4 bolts-opening of the Gearbox. Pneumatic shifting, to connect Iso 4 bolts pumps. Optional: Passing contact switch.

Datos Principales Main Data

Relación Interna Internal Ratio		1: 1,04	1: 1,26
Par nominal Torque (Nm)	Continuo Continuous	600	500
	Intermitente Intermittent	800	700
Potencia (Cv) a 1000 r.p.m. Power (HP) 1000 r.p.m		85 C.V // 64 Kw	70 C.V // 53 Kw
Lado de montaje Mounting position		Posterior Rear	
Sentido de giro de la bomba Pump rotation		Derecho Right Hand	
Peso Weight (Kg)		18	
Relación motor - Toma de Fuerza Engine to PTO ratio		ANEXO I ATTACHED I	ANEXO II ATTACHED II

Códigos y Combinaciones Codes and Combinations

Tipos de salida Output types		Eje Shaft	Plato Flange	Bomba Pump (DIN 5462)
Relación Interna Internal Ratio	1: 1,04		1022002	1022003
	1: 1,26		1021902	1021903

Toma de Fuerza Power Take Off's

código code

1022003

S5-50, S5-90, S6-65, S6-66, S6-70
S6-75, S6-80, S6-90, 6S-1000TO, 6S-1200TD/TO

ZF

Posterior Neumático
Rear Pneumatic

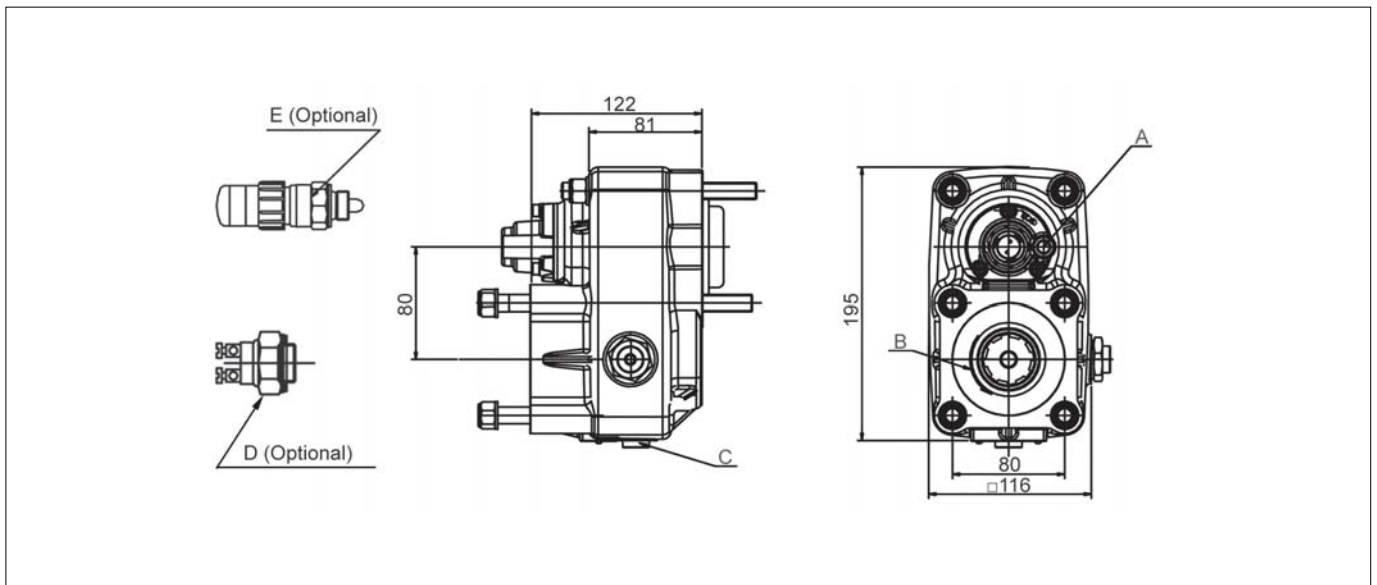

Notas Notes

Trabajo cont.-Alto par: Montar enfriador aceite		On continuous works & high torque: Install an oil cooler	
A	Toma de aire, rosca 1/4" GAS	A	Air connection, thread 1/4" BSP
B	Sentido de giro	B	Rotation
C	Tapón de drenaje del aceite	C	Oil drain plug
D	Interruptor de contacto opcional. (9024999)	D	Passing contact switch (Optional). P/N 9024999
E	Interruptor neumático (100070018)	E	Pressure switch. P/N 100070018

Tipos de Salida Output Types

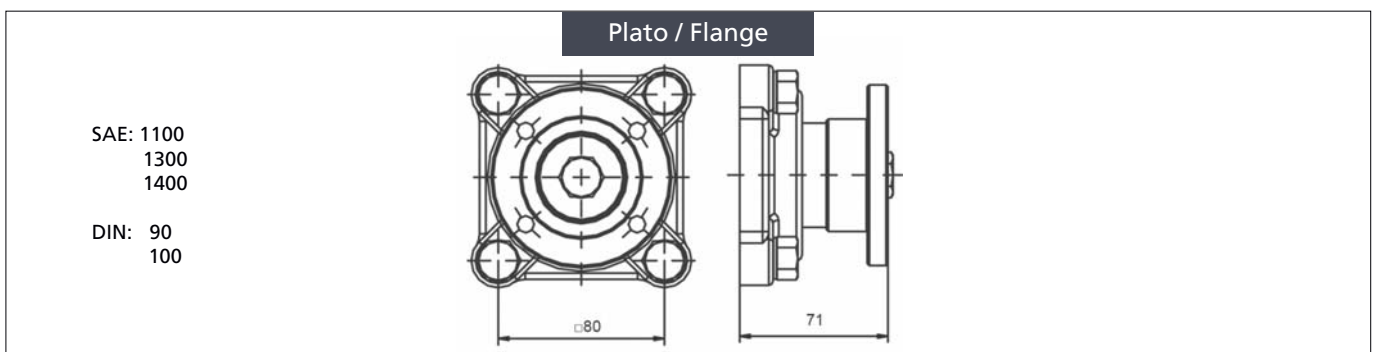

Toma de Fuerza Power Take Off's

código code

1022003

S5-50, S5-90, S6-65, S6-66, S6-70
S6-75, S6-80, S6-90, 6S-1000TO, 6S-1200TD/TO

ZF

Posterior Neumático

Rear Pneumatic

Anexo I Attached I

CAJA GEARBOX		RELACIÓN RATIO		
S5-50	/ 5.30	1: 0,679		
	/ 5.50	1: 0,640		
	/ 6.20	1: 0,567		
	/ 6.61	1: 0,530		
	/ 6.61+GV80	Larga High	1: 0,662	
		Normal Normal	1: 0,530	
	/ 8.02	1: 0,439		
/ 8.02+GV80/6.20	Larga High	1: 0,567		
	Normal Normal	1: 0,438		
S5-90GP	/ GPA	1: 0,926		
S6-65	/ 6.37	1: 0,676		
	/ 6.70	1: 0,645		
	/ 7.0+GV70/7.67	Larga High	1: 0,474	
		Normal Normal	1: 0,380	
	/ 7.40	1: 0,584		
	/ 7.52	1: 0,577		
	/ 9.00	1: 0,480		
	/ 7.97+GV80/6.70	Larga High	1: 0,645	
		Normal Normal	1: 0,546	
	/ 9.00+GV80/6.70	Larga High	1: 0,645	
Normal Normal		1: 0,480		
/ 9.00+GV80/7.52	Larga High	1: 0,576		
	Normal Normal	1: 0,480		
S6-66	/ 7.36-1.0	1: 0,543		
	/ 9.06-1.0	1: 0,433		
S6-70	/ 6.8	1: 0,535		
	/ 6.8+GV70/5.71	Larga High	1: 0,636	
		Normal Normal	1: 0,535	
	/ 7.36	1: 0,497		
	/ 7.92	1: 0,459		
	/ 9.03	1: 0,402		
/ 9.59	1: 0,380			
S6-75	/ 6.70+GV80/7.52	Normal Normal	1: 0,645	
		Corta Low	1: 0,576	
S6-80	/ 5.03	1: 0,811		
	/ 5.66	1: 0,770		

CAJA GEARBOX		RELACIÓN RATIO		
S6-80	/ 5.66+GV80/7.52	Larga High	1: 0,768	
		Normal Normal	1: 0,578	
	/ 6.10	1: 0,716		
	/ 6.7	1: 0,645		
	/ 6.7+GV80/5.30	Larga High	1: 0,818	
		Normal Normal	1: 0,645	
	/ 6.90	1: 0,536		
	/ 7.35	1: 0,574		
	/ 7.41	1: 0,586		
	/ 7.53	1: 0,577		
	/ 7.67	1: 0,562		
	/ 7.67+GV80/6.7	Larga High	1: 0,647	
		Normal Normal	1: 0,565	
	/ 7.90	1: 0,546		
	/ 9.00	1: 0,478		
	/ 9.00+GV80/5.30	Larga High	1: 0,818	
Normal Normal		1: 0,480		
/ 9.00+GV80/7.48	Larga High	1: 0,584		
	Normal Normal	1: 0,480		
/ 9.00+GV80/7.52	Larga High	1: 0,576		
	Normal Normal	1: 0,480		
S6-90	/ 5.67	1: 0,780		
	/ 5.74	1: 0,770		
	/ 6.37	1: 0,770		
	/ 6.98	1: 0,636		
	/ 7.03	1: 0,627		
	/ 7.03+GV90/5.67	Larga High	1: 0,780	
		Normal Normal	1: 0,627	
	/ 7.03+GV90/5.74	Larga High	1: 0,764	
		Normal Normal	1: 0,624	
	/ 7.40	1: 0,598		
/ 9.01	1: 0,489			
/ 9.01+GV90/7.40	Larga High	1: 0,596		
	Normal Normal	1: 0,490		
6S800TO/6,58-0,78		1: 0,551		
6S1000TO/6.75 - 0.78		1: 0,551		
6S1200TD/7.72 - 1.00		1: 0,562		
6S1200TO/6.75 - 0.83		1: 0,645		

Toma de Fuerza Power Take Off's

código code

1022003

S5-50, S5-90, S6-65, S6-66, S6-70S6-75, S6-80, S6-90
6S-800TO (Volvo ZTO 1006), 6S-1000TO, 6S-1200TD/TO
Altas Prestaciones / High Performance

ZF

Posterior Neumático

Rear Pneumatic

Anexo II Attached II

CAJA GEARBOX		RELACIÓN RATIO		
S5-50	/ 5.30	1: 0,823		
	/ 5.50	1: 0,775		
	/ 6.20	1: 0,687		
	/ 6.61	1: 0,643		
	/ 6.61+GV80	Larga High	1: 0,803	
		Normal Normal	1: 0,643	
	/ 8.02	1: 0,532		
/ 8.02+GV80/6.20	Larga High	1: 0,687		
	Normal Normal	1: 0,530		
S5-90GP	/ GPA	1: 1,121		
S6-65	/ 6.37	1: 0,819		
	/ 6.70	1: 0,781		
	/ 7.0+GV70/7.67	Larga High	1: 0,575	
		Normal Normal	1: 0,460	
	/ 7.40	1: 0,708		
	/ 7.52	1: 0,699		
	/ 9.00	1: 0,582		
	/ 7.97+GV80/6.70	Larga High	1: 0,781	
		Normal Normal	1: 0,662	
	/ 9.00+GV80/6.70	Larga High	1: 0,781	
Normal Normal		1: 0,582		
/ 9.00+GV80/7.52	Larga High	1: 0,698		
	Normal Normal	1: 0,582		
S6-66	/ 7.36-1.0	1: 0,658		
	/ 9.06-1.0	1: 0,524		
S6-70	/ 6.8	1: 0,648		
	/ 6.8+GV70/5.71	Larga High	1: 0,771	
		Normal Normal	1: 0,648	
	/ 7.36	1: 0,602		
	/ 7.92	1: 0,556		
	/ 9.03	1: 0,488		
/ 9.59	1: 0,460			
S6-75	/ 6.70+GV80/7.52	Normal Normal	1: 0,781	
		Corta Low	1: 0,698	
S6-80	/ 5.03	1: 0,983		
	/ 5.66	1: 0,932		

CAJA GEARBOX		RELACIÓN RATIO		
S6-80	/ 5.66+GV80/7.52	Larga High	1: 0,930	
		Normal Normal	1: 0,701	
	/ 6.10	1: 0,867		
	/ 6.7	1: 0,781		
	/ 6.7+GV80/5.30	Larga High	1: 0,992	
		Normal Normal	1: 0,781	
	/ 6.90	1: 0,549		
	/ 7.35	1: 0,596		
	/ 7.41	1: 0,709		
	/ 7.53	1: 0,699		
	/ 7.67	1: 0,580		
	/ 7.67+GV80/6.7	Larga High	1: 0,784	
		Normal Normal	1: 0,684	
	/ 7.90	1: 0,662		
	/ 9.00	1: 0,580		
	/ 9.00+GV80/5.30	Larga High	1: 0,992	
Normal Normal		1: 0,582		
/ 9.00+GV80/7.48	Larga High	1: 0,708		
	Normal Normal	1: 0,582		
/ 9.00+GV80/7.52	Larga High	1: 0,698		
	Normal Normal	1: 0,582		
S6-90	/ 5.67	1: 0,945		
	/ 5.74	1: 0,932		
	/ 6.37	1: 0,932		
	/ 6.98	1: 0,771		
	/ 7.03	1: 0,760		
	/ 7.03+GV90/5.67	Larga High	1: 0,945	
		Normal Normal	1: 0,760	
	/ 7.03+GV90/5.74	Larga High	1: 0,926	
		Normal Normal	1: 0,756	
	/ 7.40	1: 0,725		
/ 9.01	1: 0,592			
/ 9.01+GV90/7.40	Larga High	1: 0,722		
	Normal Normal	1: 0,593		
6S800TO/6,58-0,78(Volvo ZTO 1006)		1: 0,568		
6S1000TO/6.75 - 0.78		1: 0,668		
6S1200TD/7.72 - 1.00		1: 0,580		
6S1200TO/6.75 - 0.83		1: 0,781		