

# Toma de Fuerza Power Take Off's

código code

**1022203**

AS-TRONIC

12 AS 1800 / 16 AS 2200 / 12 AS 2301 / 16 AS 2601

9 Tal. Altas Prestaciones / 9 Bolt. high Perf

**ZF**

Posterior Neumático con ó sin Intarder  
Rear Pneumatic with or without Intarder



## Descripción Description

Toma de fuerza reforzada de 2 piñones, 2 relaciones internas para montar en el registro frontal de 9 taladros de la caja de cambios. Accionamiento neumático, para montar bombas ISO 4 taladros. Indicador de funcionamiento opcional.

Heavy Duty Power Take-off 2 gears, with two internal ratios mounting on rear 9 bolts-opening of the Gearbox. Pneumatic shifting, to connect Iso 4 bolts pumps. Optional: Passing contact switch.

### Datos Principales Main Data

Relación Interna Internal Ratio		1:1,04	1:1,26
Par nominal Torque (Nm)	Continuo Continuous	600	500
	Intermitente Intermittent	800	700
Potencia (Cv) a 1000 r.p.m. Power (HP) 1000 r.p.m		85 C.V // 64 Kw	70 C.V // 52 Kw
Lado de montaje Mounting position		Posterior Rear	
Sentido de giro de la bomba Pump rotation		Derecho Right Hand	
Peso Weight (Kg)		18	
Relación Motor - Toma de Fuerza Engine to PTO ratio		ANEXO I ATTACHED I	ANEXO II ATTACHED II

### Códigos y Combinaciones Codes and Combinations

Tipos de salida Output types		Eje Shaft	Plato Flange	Bomba Pump (DIN 5462)
Relación Internal Internal Ratio	1: 1,04		1022202	1022203
	1: 1,26		1022302	1022303

# Toma de Fuerza Power Take Off's

código code

1022203

AS-TRONIC

12 AS 1800 / 16 AS 2200 / 12 AS 2301 / 16 AS 2601  
9 Tal. Altas Prestaciones / 9 Bolt. high Perf

ZF

Posterior Neumático con ó sin Intarder  
Rear Pneumatic with or without Intarder

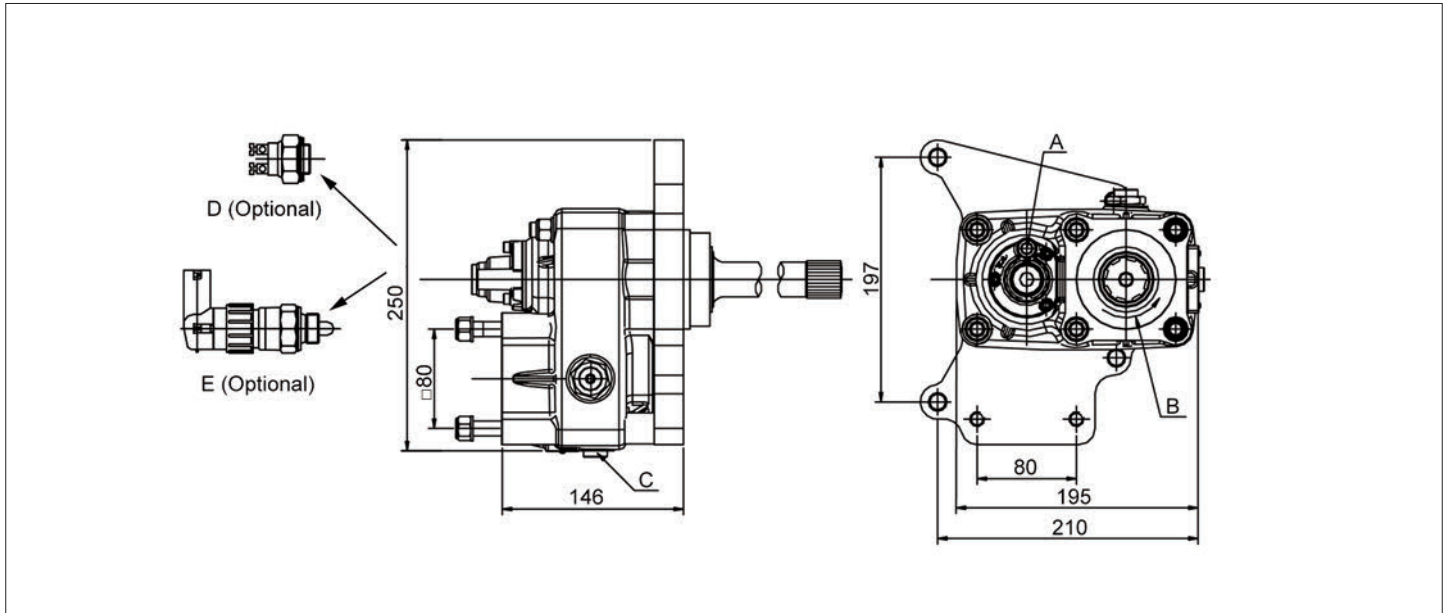

## Notas Notes

Trabajo cont.-Alto par: Montar enfriador aceite		On continuous works & high torque: Install an oil cooler	
A	Toma de aire, rosca 1/8" GAS	A	Air connection, thread 1/8" BSP
B	Sentido de giro	B	Rotation
C	Tapón de drenaje del aceite	C	Oil drain plug
D	Interruptores neumático (100070018)	D	Pressure switch. P/N 100070018
E	Interruptores de contacto (9024999)	E	Passing contact switches. P/N 9024999

## Tipos de Salida Output Types

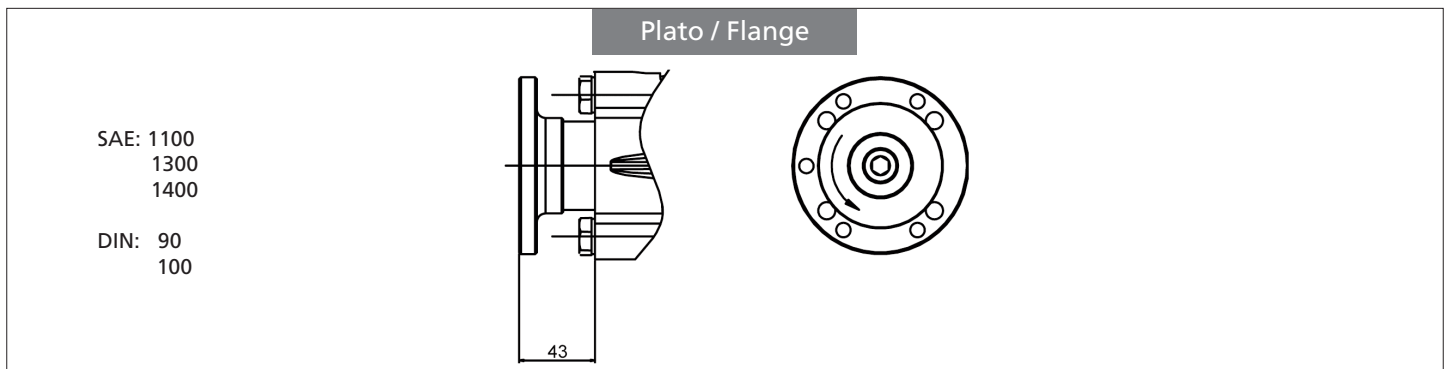

# Toma de Fuerza Power Take Off's

código code

1022203

AS-TRONIC  
12 AS 1800 / 16 AS 2200 / 12 AS 2301 / 16 AS 2601  
9 Tal. Altas Prestaciones / 9 Bolt. high Perf

ZF

Posterior Neumático con ó sin Intarder  
Rear Pneumatic with or without Intarder

## Anexo I Attached I

Relación motor - Toma de Fuerza Engine to PTO ratio	12AS-1630 TD/ 1930 TD/ 2130 TD/ 2140 TD / 2340 TD/ 2430 TD/ 2540 TD	/15.86-1.0	1: 1.148
	12AS-1631 TD/ 1931 TD/ 2131 TD/ 2141 TD / 2301 TD/ 2341 TD/ 2431 TD (+IT)		
	12AS-1800	/14.89-1.0	1: 0.790
	12AS-1800 (+IT)		
	12AS-1930 TO/2130 TO/2330 TO / 2530 TO	/12.33-0.78	1: 1.404
	12AS-1931 TO/2131 TO/2301 TO 2331 TO/ 2531 TO (+IT)		
	12AS-2540 TO/ 2740 TO/ 2940 TO	/12.29-0.78	1: 1404
	12AS-2541 TO/ 2741 TO/ 2941 TO (+IT)		
	16AS-2200	/15.89-1.0	1: 0.738
	16AS-2200 (+IT)		
	16AS-2230 TD/ 2601 TD	/17.03-1.0	1: 0.790
	16AS-2231 TD/ 2601 TD (+IT)		
	16AS-2601 TO/ 2630 TO	/14.12-0.83	1: 1.154
	16AS-2601 TO/ 2631 TO (+IT)		

## Anexo II Attached II

Relación motor - Toma de Fuerza Engine to PTO ratio	12AS-1630 TD/ 1930 TD/ 2130 TD/ 2140 TD / 2340 TD/ 2430 TD/ 2540 TD	/15.86-1.0	1: 1.033
	12AS-1631 TD/ 1931 TD/ 2131 TD/ 2141 TD / 2301 TD/ 2341 TD/ 2431 TD (+IT)		
	12AS-1800	/14.89-1.0	1: 0.957
	12AS-1800 (+IT)		
	12AS-1930 TO/2130 TO/2330 TO / 2530 TO	/12.33-0.78	1: 1.701
	12AS-1931 TO/2131 TO/2301 TO 2331 TO/ 2531 TO (+IT)		
	12AS-2540 TO/ 2740 TO/ 2940 TO	/12.29-0.78	1: 1.701
	12AS-2541 TO/ 2741 TO/ 2941 TO (+IT)		
	16AS-2200	/15.89-1.0	1: 0.894
	16AS-2200 (+IT)		
	16AS-2230 TD/ 2601 TD	/17.03-1.0	1: 0.957
	16AS-2231 TD/ 2601 TD (+IT)		
	16AS-2601 TO/ 2630 TO	/14.12-0.83	1: 1.398
	16AS-2601 TO/ 2631 TO (+IT)		