

código code

1023203

S5 - 35

ZF

Posterior Neumático
Rear Pneumatic



Descripción Description

Toma de fuerza de un piñon, para montar bombas Iso 4 taladros. Accionamiento neumático, montaje en el registro frontal de 4 taladros de la caja de cambios. Indicador de funcionamiento opcional.

Power Take-off one gear, to connect Iso 4 bolts pumps. Pneumatic shifting, mounting on rear 4 bolts-window of the Gearbox. Optional: Passing contact switch.

Datos Principales Main Data

Par nominal Torque (Nm)	Continuo Continuous	430
	Intermitente Intermittent	602
Potencia (Cv) a 1000 r.p.m. Power (HP) 1000 r.p.m		61 C.V // 45 Kw
Lado de montaje Mounting position		Posterior Rear
Sentido de giro de la bomba Pump rotation		Izquierdo Left Hand
Peso Weight (Kg)		5
Relación motor - Toma de Fuerza Engine to PTO ratio	S5-35 / 5.64	1:0,628
	S5-35 / 6.45	1:0,550
	S5-35 / 6.75	1:0,525
	S5-35 / 6.79	1:0,666
	S5-35 / 7.65	1:0,462
	S5-35 / 8.02	1:0,440

Códigos y Combinaciones Codes and Combinations

Tipos de salida Output types	Eje Shaft	Plato Flange	Bomba Pump (DIN 5462)
Accionamiento neumático Pneumatic shifting		1023202	1023203

Toma de Fuerza Power Take Off's

código code

1023203

S5 - 35

ZF

Posterior Neumático
Rear Pneumatic

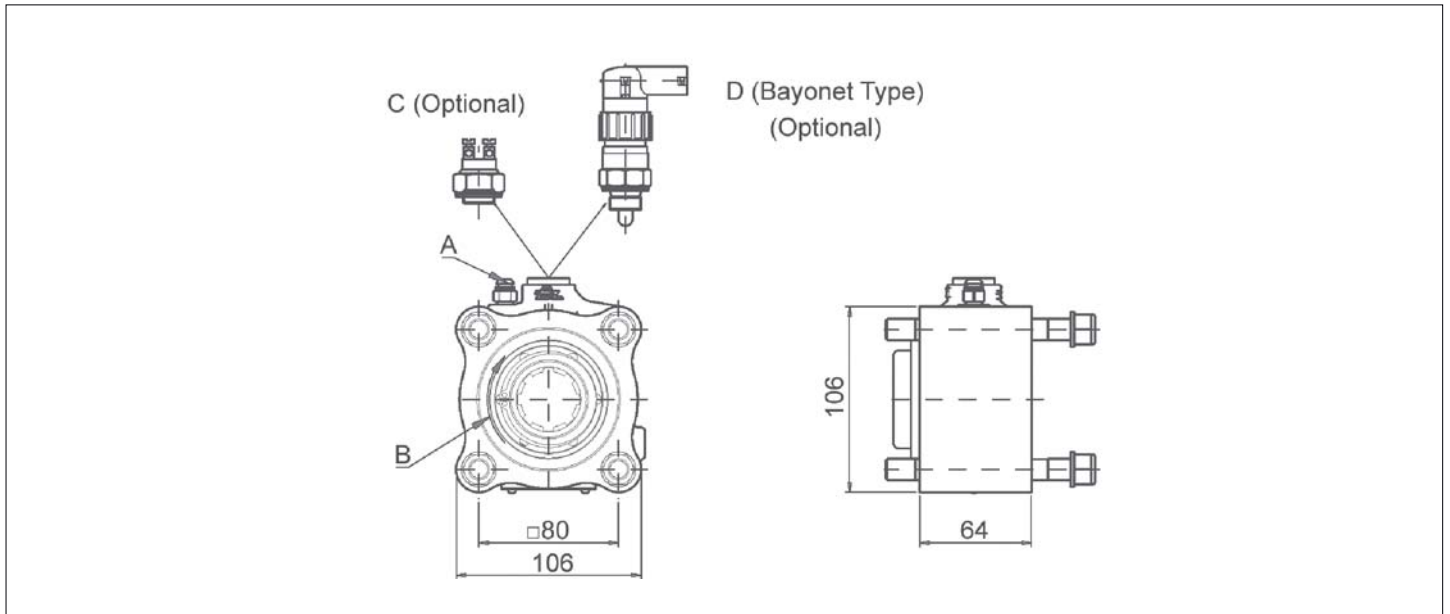

Notas Notes

A	Toma de aire, rosca 1/8" GAS	A	Air connection, thread 1/8" BSP
B	Sentido de giro	B	Rotation
C	Interruptor neumático. (100070018)	C	Pressure switch. P/N 100070018
D	Interruptor de contacto. (9024999)	D	Passing contact switch. P/N 9024999

Tipos de Salida Output Types

Adaptador Plato / Flange Adapter

FLANGE TYPE		CODE
SAE:	1100	7015504
	1300	
	1400	
DIN:	90	7015804
	100	7015704

