

Toma de Fuerza Power Take Off's

código code

1019103

S5-50, S5-90, S6-65, S6-66, S6-70S6-75, S6-80, S6-90
6S-800TO (Volvo ZTO 1006), 6S-1000TO, 6S-1200TD/TO

ZF

Posterior Neumático con Embrague
Rear Pneumatic Clutch Shift



Descripción Description

Toma de fuerza de dos piñones, con embrague incorporado y diferentes relaciones internas para montar bombas ISO 4 taladros. Accionamiento neumático, montaje sobre el registro frontal de 4 taladros de la caja de cambios.

Hot shift Power Take-off two gears with different internal ratios to connect Iso 4 bolts pumps. Pneumatic shifting, mounting on rear 4 bolts-window of the Gearbox.

Datos Principales Main Data

Par nominal Torque (Nm)	Continuo Continuous	400
	Intermitente Intermittent	560
Potencia (Cv) a 1000 r.p.m. Power (HP) 1000 r.p.m	57 C.V // 42 Kw	
Lado de montaje Mounting position	Posterior Rear	
Sentido de giro de la bomba Pump rotation	Derecho Right Hand	
Peso Weight (Kg)	19	
Relación motor - Toma de Fuerza Engine to PTO ratio	ANEXO ATTACHED	

Códigos y Combinaciones Codes and Combinations

Tipos de salida Output types	Eje Shaft	Plato Flange	Bomba Pump (DIN 5462)
Relación Internal Internal ratio	1:1,85	1019102	1019103
	1:1,35	1023702	1023703

No es posible combinar esta toma de fuerza con el eje para cajas de cambios Astronic
This PTO cannot be combined with adapter kit for Astronic gearboxes

Toma de Fuerza Power Take Off's

código code

1019103

S5-50, S5-90, S6-65, S6-66, S6-70S6-75, S6-80, S6-90
6S-800TO (Volvo ZTO 1006), 6S-1000TO, 6S-1200TD/TO

ZF

Posterior Neumático con Embrague
Rear Pneumatic Clutch Shift

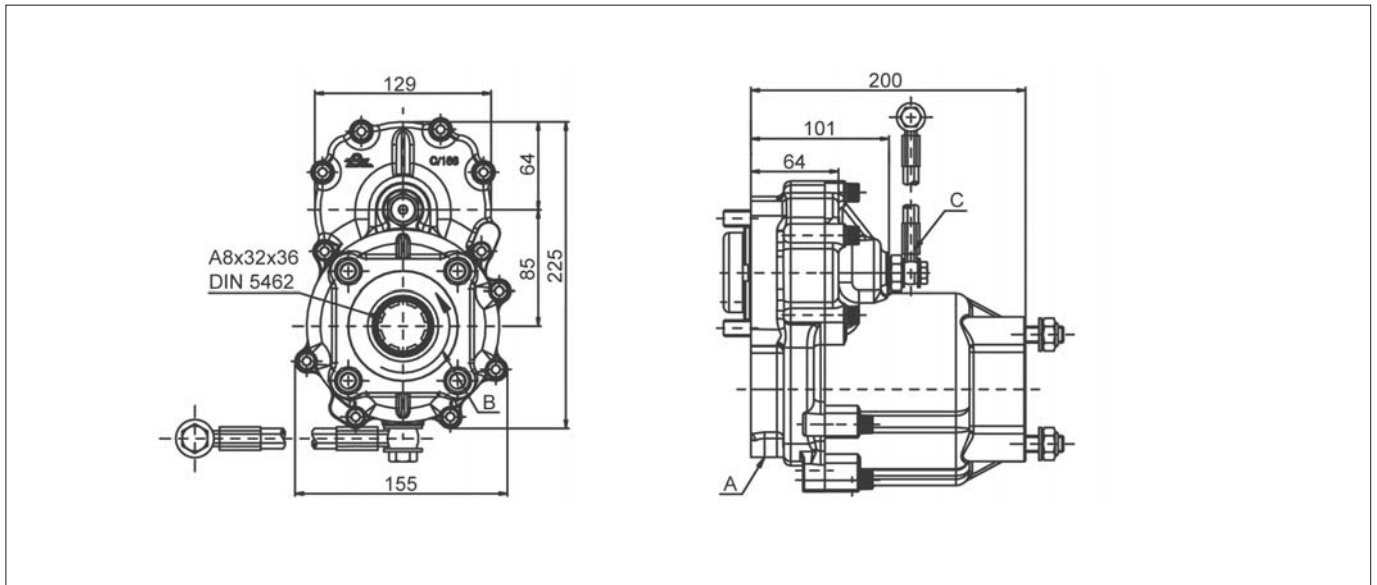

Notas Notes

A	Toma de aire, rosca 1/4" GAS	A	Air connection, thread 1/4" BSP
B	Sentido de giro	B	Rotation
C	Kit Lubricación 900199	C	Lubrication Kit 900199

Importante: Una bomba superior a 12 kg. necesita ser instalada sobre soportes
Warning: A pump with a weight over 12 kg. need to be supported by brackets.

Tipos de Salida Output Types

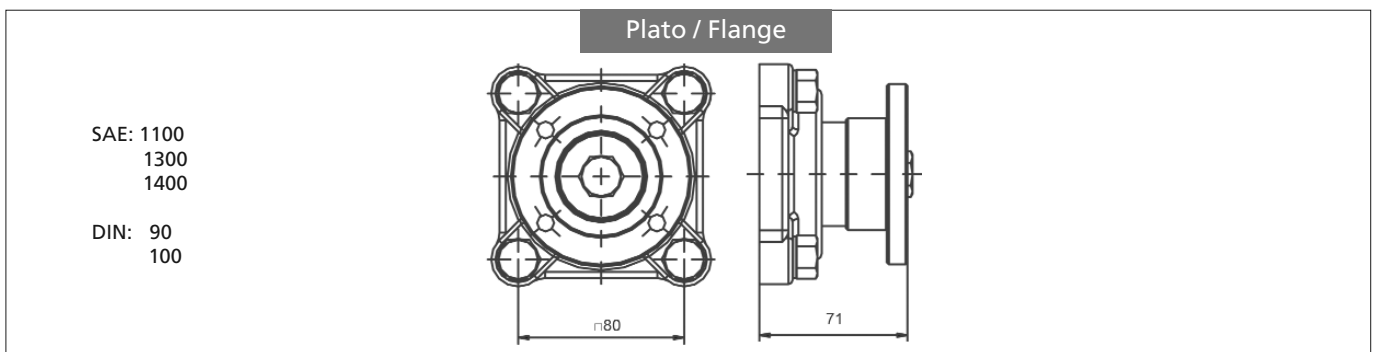

SAE: 1100
1300
1400

DIN: 90
100

BZ
bezares s.a.

Av. de las Retamas. Parcela:145. 45950. Casarrubios del Monte. Toledo (Spain) Tlf: +34 902 333 331
www.bezares.com bezares@bezares.com

24.13.12

Toma de Fuerza Power Take Off's

código code

1019103

S5-50, S5-90, S6-65, S6-66, S6-70S6-75, S6-80, S6-90
6S-800TO (Volvo ZTO 1006), 6S-1000TO, 6S-1200TD/TO

ZF

Posterior Neumático con Embrague

Rear Pneumatic Clutch Shift

	CAJA GEARBOX	RELACIÓN 1:1,85 RATIO 1:1,85	
S5-50	/ 5.30	1: 1,208	
	/ 5.50	1: 1,138	
	/ 6.20	1: 1,008	
	/ 6.61	1: 0,944	
	/ 6.61+GV80	Larga High	1: 1,178
		Normal Normal	1: 0,944
	/ 8.02	1: 0,781	
/ 8.02+GV80/6.20	Larga High	1: 1,008	
	Normal Normal	1: 0,779	
S5-90GP	/ GPA	1: 1,647	
S6-65	/ 6.37	1: 1,203	
	/ 6.70	1: 1,147	
	/ 7.0+GV70/7.67	Larga High	1: 0,844
		Normal Normal	1: 0,675
	/ 7.40	1: 1,040	
	/ 7.52	1: 1,027	
	/ 9.00	1: 0,855	
	/ 7.97+GV80/6.70	Larga High	1: 1,147
		Normal Normal	1: 0,971
	/ 9.00+GV80/6.70	Larga High	1: 1,147
		Normal Normal	1: 0,855
	/ 9.00+GV80/7.52	Larga High	1: 1,025
		Normal Normal	1: 0,855
S6-66	/ 7.36-1.0	1: 0,966	
	/ 9.06-1.0	1: 0,770	
S6-70	/ 6.8	1: 0,951	
	/ 6.8+GV70/5.71	Larga High	1: 1,132
		Normal Normal	1: 0,951
	/ 7.36	1: 0,884	
	/ 7.92	1: 0,816	
	/ 9.03	1: 0,716	
/ 9.59	1: 0,675		
S6-75	/ 6.70+GV80/7.52	Normal Normal	1: 1,147
		Corta Low	1: 1,025
S6-80	/ 5.03	1: 1,443	
	/ 5.66	1: 1,369	

	CAJA GEARBOX	RELACIÓN 1:1,85 RATIO 1:1,85	
S6-80	/ 5.66+GV80/7.52	Larga High	1: 1,365
		Normal Normal	1: 1,029
	/ 6.10	1: 1,273	
	/ 6.7	1: 1,147	
	/ 6.7+GV80/5.30	Larga High	1: 1,456
		Normal Normal	1: 1,147
	/ 6.90	1: 0,953	
	/ 7.35	1: 1,021	
	/ 7.41	1: 1,042	
	/ 7.53	1: 1,027	
	/ 7.67	1: 0,999	
	/ 7.67+GV80/6.7	Larga High	1: 1,151
		Normal Normal	1: 1,005
	/ 7.90	1: 0,971	
	/ 9.00	1: 0,851	
	/ 9.00+GV80/5.30	Larga High	1: 1,456
		Normal Normal	1: 0,855
/ 9.00+GV80/7.48	Larga High	1: 1,040	
	Normal Normal	1: 0,855	
/ 9.00+GV80/7.52	Larga High	1: 1,025	
	Normal Normal	1: 0,855	
S6-90	/ 5.67	1: 1,388	
	/ 5.74	1: 1,369	
	/ 6.37	1: 1,369	
	/ 6.98	1: 1,132	
	/ 7.03	1: 1,116	
	/ 7.03+GV90/5.67	Larga High	1: 1,388
		Normal Normal	1: 1,116
	/ 7.03+GV90/5.74	Larga High	1: 1,360
		Normal Normal	1: 1,110
	/ 7.40	1: 1,064	
/ 9.01	1: 0,870		
S6-75	/ 6.70+GV80/7.52	Larga High	1: 1,060
		Normal Normal	1: 0,871
6S800TO/6.58-0.78(Volvo ZTO 1006)		1: 0,981	
6S1000TO/6.75 - 0.78		1: 0,981	
6S1200TD/7.72 - 1.00		1: 0,999	
6S1200TO/6.75 - 0.83		1: 1,147	

Toma de Fuerza Power Take Off's

código code

1019103

S5-50, S5-90, S6-65, S6-66, S6-70S6-75, S6-80, S6-90
6S-800TO (Volvo ZTO 1006), 6S-1000TO, 6S-1200TD/TO

ZF

Posterior Neumático con Embrague
Rear Pneumatic Clutch Shift

CAJA GEARBOX		RELACIÓN 1:1,35 RATIO 1:1,35	
S5-50	/ 5.30	1: 0,881	
	/ 5.50	1: 0,830	
	/ 6.20	1: 0,735	
	/ 6.61	1: 0,688	
	/ 6.61+GV80	Larga High	1: 0,859
		Normal Normal	1: 0,688
	/ 8.02	1: 0,569	
	/ 8.02+GV80/6.20	Larga High	1: 0,735
Normal Normal		1: 0,568	
S5-90GP	/ GPA	1: 1,201	
S6-65	/ 6.37	1: 0,877	
	/ 6.70	1: 0,837	
	/ 7.0+GV70/7.67	Larga High	1: 0,615
		Normal Normal	1: 0,492
	/ 7.40	1: 0,758	
	/ 7.52	1: 0,749	
	/ 9.00	1: 0,623	
	/ 7.97+GV80/6.70	Larga High	1: 0,837
		Normal Normal	1: 0,708
	/ 9.00+GV80/6.70	Larga High	1: 0,837
Normal Normal		1: 0,623	
/ 9.00+GV80/7.52	Larga High	1: 0,747	
	Normal Normal	1: 0,623	
S6-66	/ 7.36-1.0	1: 0,704	
	/ 9.06-1.0	1: 0,561	
S6-70	/ 6.8	1: 0,693	
	/ 6.8+GV70/5.71	Larga High	1: 0,826
		Normal Normal	1: 0,693
	/ 7.36	1: 0,645	
	/ 7.92	1: 0,595	
	/ 9.03	1: 0,522	
/ 9.59	1: 0,492		
S6-75	/ 6.70+GV80/7.52	Normal Normal	1: 0,837
		Corta Low	1: 0,747
S6-80	/ 5.03	1: 1,053	
	/ 5.66	1: 0,999	

CAJA GEARBOX		RELACIÓN 1:1,35 RATIO 1:1,35	
S6-80	/ 5.66+GV80/7.52	Larga High	1: 0,996
		Normal Normal	1: 0,750
	/ 6.10	1: 0,928	
	/ 6.7	1: 0,837	
	/ 6.7+GV80/5.30	Larga High	1: 1,062
		Normal Normal	1: 0,837
	/ 6.90	1: 0,695	
	/ 7.35	1: 0,745	
	/ 7.41	1: 0,760	
	/ 7.53	1: 0,749	
	/ 7.67	1: 0,729	
	/ 7.67+GV80/6.7	Larga High	1: 0,839
		Normal Normal	1: 0,733
	/ 7.90	1: 0,708	
	/ 9.00	1: 0,621	
	/ 9.00+GV80/5.30	Larga High	1: 1,062
Normal Normal		1: 0,623	
/ 9.00+GV80/7.48	Larga High	1: 0,758	
	Normal Normal	1: 0,623	
/ 9.00+GV80/7.52	Larga High	1: 0,747	
	Normal Normal	1: 0,623	
S6-90	/ 5.67	1: 1,012	
	/ 5.74	1: 0,999	
	/ 6.37	1: 0,999	
	/ 6.98	1: 0,826	
	/ 7.03	1: 0,814	
	/ 7.03+GV90/5.67	Larga High	1: 1,012
		Normal Normal	1: 0,814
	/ 7.03+GV90/5.74	Larga High	1: 0,992
		Normal Normal	1: 0,81
	/ 7.40	1: 0,776	
/ 9.01	1: 0,634		
/ 9.01+GV90/7.40	Larga High	1: 0,773	
	Normal Normal	1: 0,635	
6S800TO/6,58-0,78(Volvo ZTO 1006)		1: 0,715	
6S1000TO/6.75 - 0.78		1: 0,715	
6S1200TD/7.72 - 1.00		1: 0,729	
6S1200TO/6.75 - 0.83		1: 0,837	