

Toma de Fuerza Power Take Off's

código code

1027403

AS-TRONIC
12 AS 1800 / 16 AS 2200 / 12 AS 2301 / 16 AS 2601
5 Tal. Altas Prestaciones / 5 Bolt. high Perf

ZF

Posterior Neumático con ó sin Intarder
Rear Pneumatic with or without Intarder

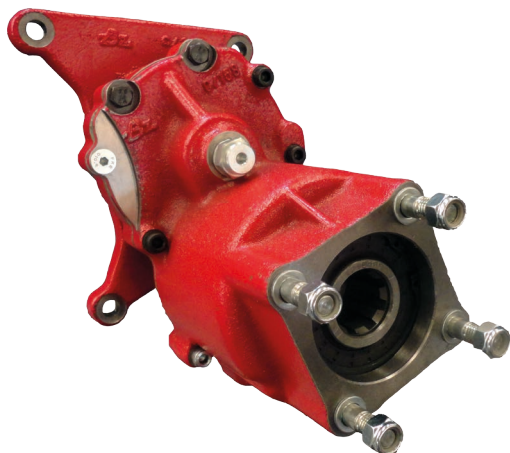

Descripción Description

Toma de fuerza de alta potencia con embrague incorporado, montaje en registro frontal de 5 taladros de la caja de cambios. Accionamiento neumático. Válida para cajas de cambios con y sin intarder.

High Power, built-in clutch PTO, mounting on 5 bolts flange of the gearbox. Pneumatic shifting. Valid for gearboxes with and without intarder.

Datos Principales Main Data

Relación Interna Internal Ratio		1:1,35
Par nominal Torque (Nm)	Continuo Continuous	400
	Intermitente Intermittent	560
Potencia (Cv) a 1000 r.p.m. Power (HP) 1000 r.p.m		57 CV // 42 kW
Lado de montaje Mounting position		Posterior Rear
Sentido de giro de la bomba Pump rotation		Derecho Clockwise
Peso Weight (Kg)		23
Relación Motor - Toma de Fuerza Engine to PTO ratio		ANEXO ATTACHMENT

Códigos y Combinaciones Codes and Combinations

Tipos de salida Output types	Plato Flange	Bomba Pump (DIN 5462)
Relación Internal Internal Ratio	1027402	1027403

Toma de Fuerza Power Take Off's

código code

1027403

AS-TRONIC

12 AS 1800 / 16 AS 2200 / 12 AS 2301 / 16 AS 2601

5 Tal. Altas Prestaciones / 5 Bolt. high Perf

ZF

Posterior Neumático con ó sin Intarder
Rear Pneumatic with or without Intarder

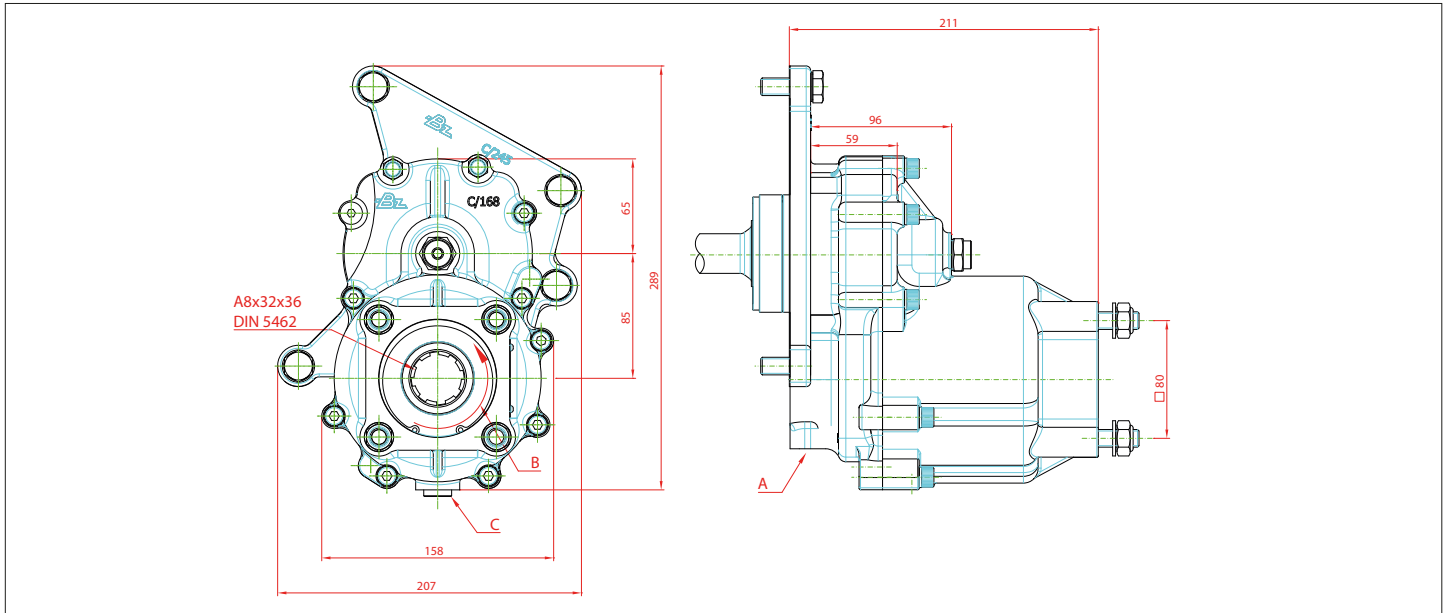

Notas Notes

A	Toma de aire, rosca 1/4" GAS	A	Air connection, thread 1/4" BSP
B	Sentido de giro	B	Rotation
C	Tapón de drenaje del aceite	C	Oil drain plug

Importante: Una bomba superior a 16 kg. necesita ser instalada sobre soportes
Warning: A pump with a weight over 16 kg. need to be supported by brackets.

Tipos de Salida Output Types

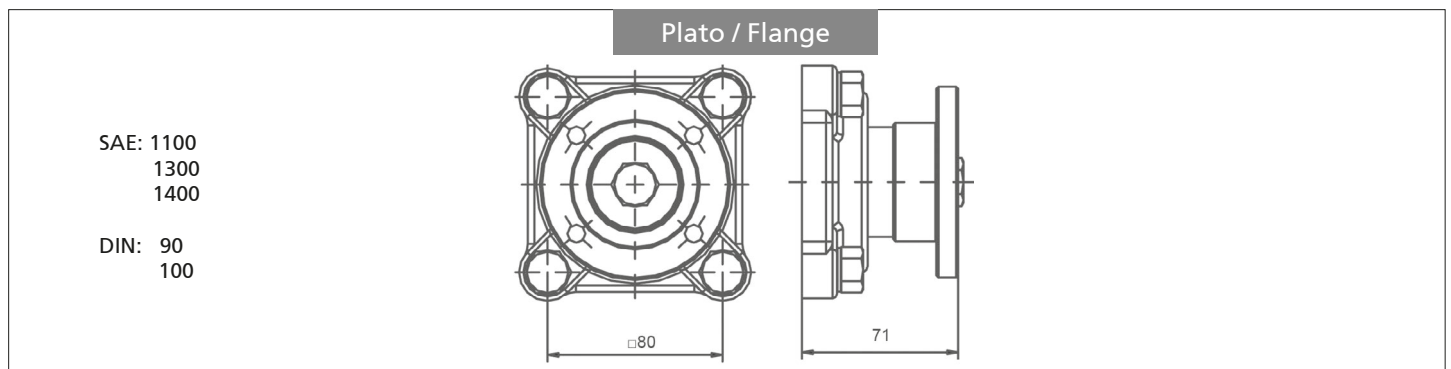

Toma de Fuerza Power Take Off's

código code

1027403

AS-TRONIC

12 AS 1800 / 16 AS 2200 / 12 AS 2301 / 16 AS 2601
5 Tal. Altas Prestaciones / 5 Bolt. high Perf

ZF

Posterior Neumático con ó sin Intarder
Rear Pneumatic with or without Intarder

Anexo Attachment			
Relación motor - Toma de Fuerza Engine to PTO ratio	12AS-2330 TD / 12AS-1630 TD / 1930 TD/ 2130 TD/ 2140 TD / 2340 TD/ 2430 TD/ 2540 TD	/15.86-1.0	1: 1,11
	12AS-2331 TD / 12AS-1631 TD/ 1931 TD/ 2131 TD/ 2141 TD / 2301 TD/ 2341 TD/ 2431 TD (+IT)		
	12AS-1800	/14.89-1.0	1: 1,02
	12AS-1800 (+IT)		
	12AS-1930 TO/2130 TO/2330 TO / 2530 TO	/12.33-0.78	1: 1,82
	12AS-1931 TO/2131 TO/2301 TO 2331 TO/ 2531 TO (+IT)		
	12AS-2540 TO/ 2740 TO/ 2940 TO	/12.29-0.78	1: 1,82
	12AS-2541 TO/ 2741 TO/ 2941 TO (+IT)		
	16AS-2200	/15.89-1.0	1: 0,96
	16AS-2200 (+IT)		
	16AS-2230 TD/ 2601 TD	/17.03-1.0	1: 1,02
	16AS-2231 TD/ 2601 TD (+IT)		
	16AS-2601 TO/ 2630 TO	/14.12-0.83	1: 1,50
	16AS-2601 TO/ 2631 TO (+IT)		