

Toma de Fuerza Power Take Off's

código code

115703

R1000, R1400, R1700, SR1400, SR1700, SR1900,
SR2000, SRO2400, VT1708, VT2009B, VT2014B,
VT2214, VT2412B, VT2514B

Volvo

Posterior Neumático con Embrague
Rear Pneumatic Clutch Shift



Descripción Description

Toma de fuerza de dos piñones, con embrague incorporado, para montar bombas ISO 4 taladros. Accionamiento neumático, montaje sobre el registro frontal de 4 taladros de la caja de cambios.

Power Take-off two gears, clutch shift pto, to connect Iso 4 bolts pumps. Pneumatic shifting, mounting on rear 4 bolts-window of the Gearbox.

Datos Principales Main Data

Par nominal Torque (Nm)	Continuo Continuous		400	
	Intermitente Intermittent		560	
Potencia (Cv) a 1000 r.p.m. Power (HP) 1000 r.p.m			57 C.V // 42 Kw	
Lado de montaje Mounting position			Posterior Rear	
Sentido de giro de la bomba Pump rotation			Derecho Right Hand	
Peso Weight (Kg)			23	
Relación motor - Toma de Fuerza Engine to PTO ratio	R1000, R1400, R1700		1: 1,295	1: 0,945
	SR1400, SR1700,SR1900	Larga High	1: 1,628	1: 1,188
		Normal Normal	1: 1,295	1: 0,945
	SR2000	Larga High	1: 1,517	1: 1,107
		Normal Normal	1: 1,203	1: 0,877
	SRO2400	Larga High	1: 1,906	1: 1,390
		Normal Normal	1: 1,517	1: 1,107
	VT1708, VT2009B		1: 1,295	1: 0,945
	VT2014B, VT2214B	Larga High	1: 1,628	1: 1,350
		Normal Normal	1: 1,295	1: 0,945
	VT2412B	Larga High	1: 1,671	1: 1,219
		Normal Normal	1: 1,295	1: 0,945
	VT2514B	Larga High	1: 1,628	1: 1,188
		Normal Normal	1: 1,295	1: 0,945
VTO2214B, VTO2514B	Larga High	1: 2,024	1: 1,477	
	Normal Normal	1: 1,628	1: 1,188	
Relación Interna Internal ratio			1:1'85	1:1'35

Códigos y Combinaciones Codes and Combinations

Tipos de salida Output types	Eje Shaft	Plato Flange	Bomba Pump (DIN 5462)
Relación Interna Internal ratio	1:1'85	115702	115703
	1:1'35	119002	119003

BZ
bezares s.a.

Av. de las Retamas. Parcela:145. 45950. Casarrubios del Monte. Toledo (Spain) Tlf: +34 91 818 82 97
www.bezares.com bezares@bezares.com

23.4.7

Toma de Fuerza Power Take Off's

código code

115703

R1000, R1400, R1700, SR1400, SR1700, SR1900,
SR2000, SRO2400, VT1708, VT2009B, VT2014B,
VT2214, VT2412B, VT2514B

Volvo

Posterior Neumático con Embrague
Rear Pneumatic Clutch Shift

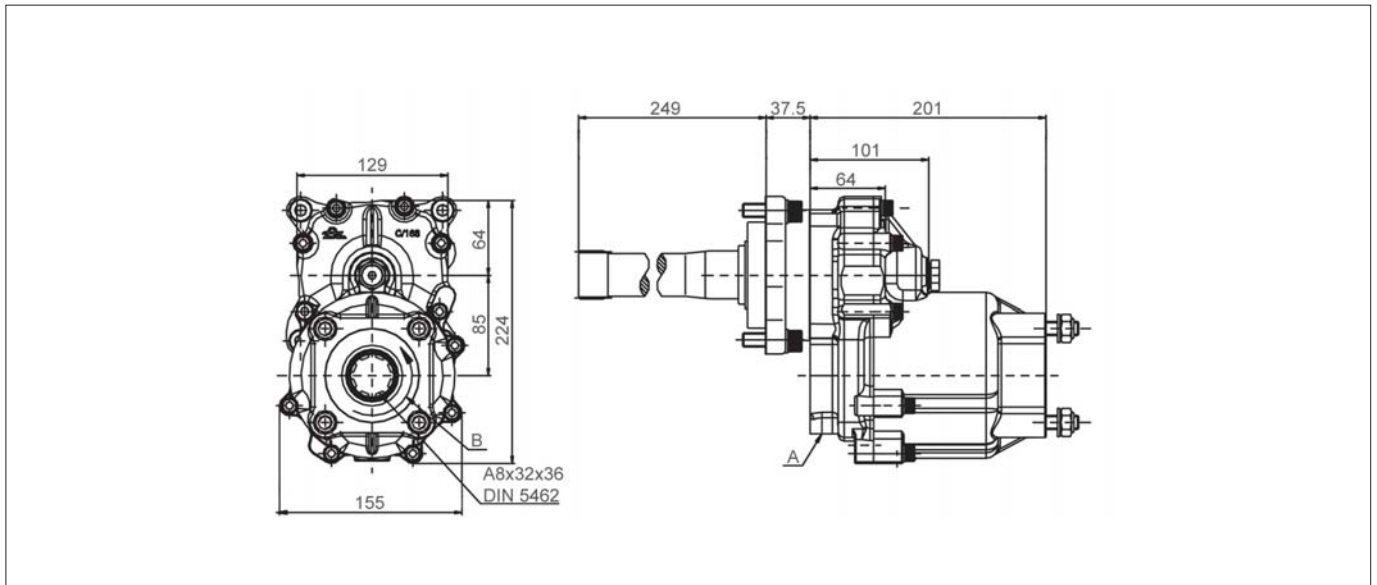

Notas Notes

A	Toma de aire, rosca 1/4" GAS	A	Air connection, thread 1/4" BSP
B	Sentido de giro	B	Rotation

Importante: Una bomba superior a 12 kg. necesita ser instalada sobre soportes
Warning: A pump with a weight over 12 kg. need to be supported by brackets.

Tipos de Salida Output Types

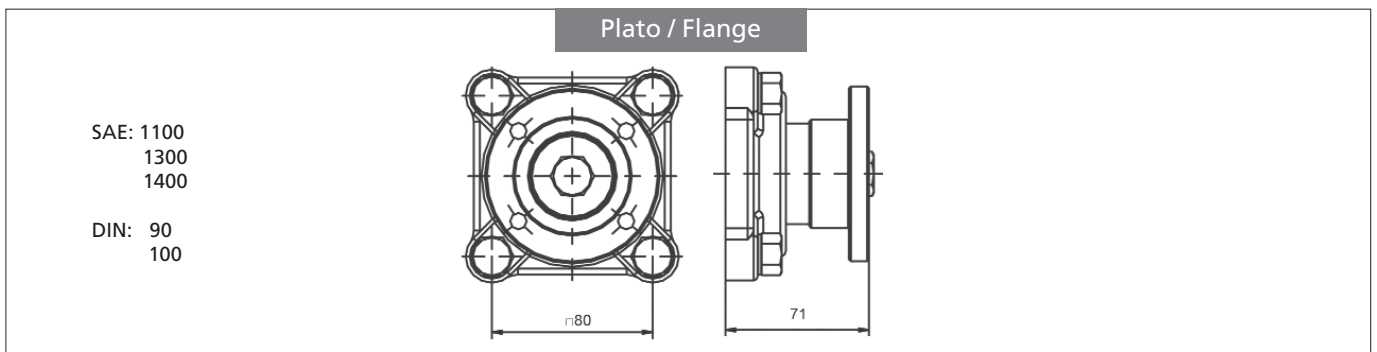

SAE: 1100
1300
1400

DIN: 90
100

BZ
bezares s.a.

Av. de las Retamas. Parcela:145. 45950. Casarrubios del Monte. Toledo (Spain) Tlf: +34 91 818 82 97
www.bezares.com bezares@bezares.com

23.4.7