

Toma de Fuerza Power Take Off's

código code

1196K03

DT-2412C, R1000, R1400, R1700, SR1400, SR1700, SR1900, SR2000, SRO2400, V/VO2512AT, V2812AT, VO3112AT, VT1708, VT2009B, VT2014B, VT2214, VT2412B, VT2514B

Volvo

Posterior Neumático (1:1)

Rear Pneumatic



Descripción Description

Kit de toma de fuerza + brida (sin eje) toma constante 1:1 montaje en registro frontal de 4 taladros de la caja de cambios. Accionamiento neumático, salida ISO 4 taladros. Indicador de funcionamiento y eje adaptador opcional.

Base PTO + flange Kit (without shaft) constant mesh 1:1 mounting on rear 4 bolts-window of the Gearbox. Pneumatic shifting, output Iso 4 bolts. Optional: Passing contact switch and adapter shaft.

Datos Principales Main Data

Par nominal Torque (Nm)	Continuo Continuous	590	
	Intermitente Intermittent	826	
Potencia (Cv) a 1000 r.p.m. Power (HP) 1000 r.p.m		84 C.V // 62 Kw	
Lado de montaje Mounting position		Posterior Rear	
Sentido de giro de la bomba Pump rotation		Izquierdo Left Hand	
Peso Weight (Kg)		8	
Relación motor - Toma de Fuerza Engine to PTO ratio	R1000, R1400, R1700	1: 0,700	
	SR1400, SR1700, SR1900, VT2014B, VT2214B, VT2514B, DT-2412C	Larga High	1: 0,880
		Normal Normal	1: 0,700
	SR2000	Larga High	1: 0,820
		Normal Normal	1: 0,650
	SRO2400	Larga High	1: 1,030
		Normal Normal	1: 0,820
	VT1708, VT2009B		1: 0,700
	V2412AT, V2512AT, V2812AT, VT2412B	Larga High	1: 0,903
		Normal Normal	1: 0,700
	VO2512AT, VO3112AT	Larga High	1: 1,150
		Normal Normal	1: 0,900
VTO2214B, VTO2514B	Larga High	1: 1,094	
	Normal Normal	1: 0,880	

Códigos y Combinaciones Codes and Combinations

Kit toma de fuerza base con brida Base PTO Kit with flange		+	Kit de eje adaptador Adapter shaft kit	
			R1000, SR1700, ... (L=267mm)	110104
Salida Plato Flange output	1196K02		R1000, ... Retarder (L=302mm)	110304
Salida Bomba Pump output (DIN 5462)	1196K03		DT-2412C, V2412 (L=229 mm)	116504

Toma de Fuerza Power Take Off's

código code

1196K03

DT-2412C, R1000, R1400, R1700, SR1400, SR1700,
SR1900, SR2000, SRO2400, VVO2512AT, V2812AT,
VO3112AT, VT1708, VT2009B, VT2014B, VT2214,
VT2412B, VT2514B

Volvo

Posterior Neumático (1:1)

Rear Pneumatic

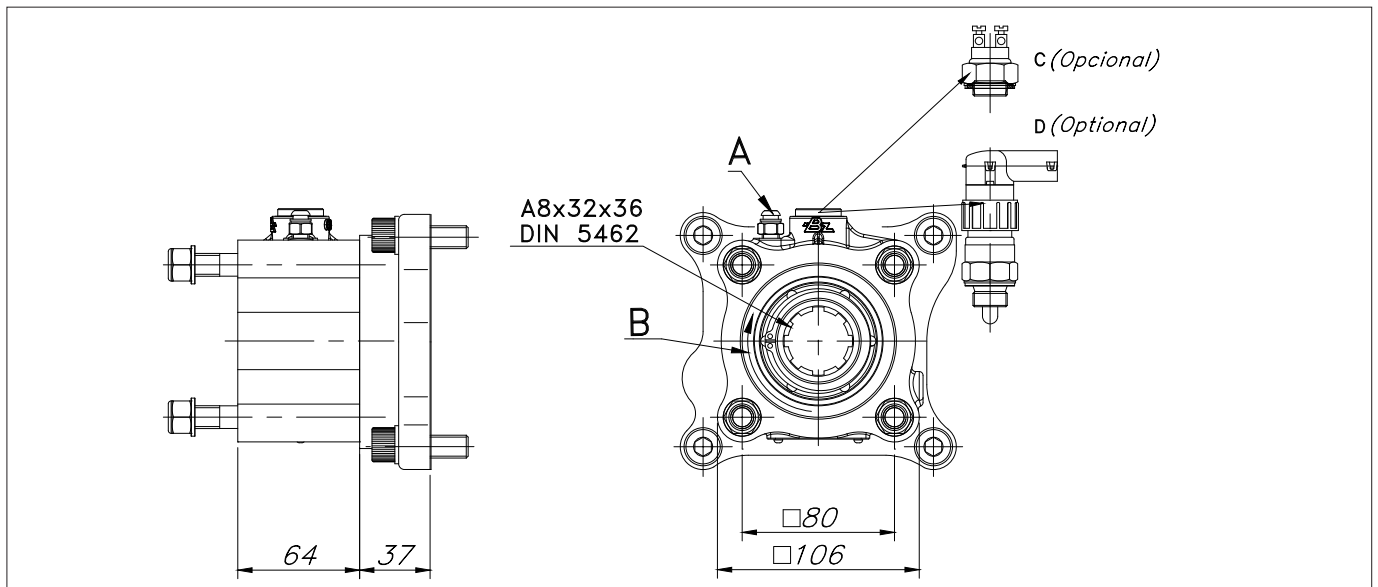

Notas Notes

A	Conexión PTO, rosca 1/8" GAS	A	Engage PTO, thread 1/8" BSP
B	Sentido de giro	B	Rotation
C	Interruptor neumático (100070018)	C	Passing contact switch. P/N 100070018
D	Interruptor de contacto (9024999)	D	Passing contact switch. P/N 9024999

Tipos de Salida Output Types

FLANGE TYPE		CODE
SAE:	1100	7015504
	1300	
	1400	7015604
DIN:	90	7015804
	100	7015704

Adaptador Plato / Flange Adapter