

Toma de Fuerza Power Take Off's

código code

1198K03

DT-2412C, R1000, R1400, R1700, SR1400, SR1700, SR1900, SR2000, SRO2400, V/VO2512AT, V2812AT, VO3112AT, VT1708, VT2009B, VT2014B, VT2214, VT2412B, VT2514B

Volvo

Posterior Neumático (1: 1,32)

Rear Pneumatic



Descripción Description

Kit de toma de fuerza + brida (sin eje) toma constante 1:1.32 montaje en registro frontal de 4 taladros de la caja de cambios. Accionamiento neumático, salida ISO 4 taladros. Indicador de funcionamiento y eje adaptador opcional.

Base PTO + flange Kit (without shaft) constant mesh 1:1.32 mounting on rear 4 bolts-window of the Gearbox. Pneumatic shifting, output Iso 4 bolts. Optional: Passing contact switch and adapter shaft.

Datos Principales Main Data

Par nominal Torque (Nm)	Continuo Continuous	300	
	Intermitente Intermittent	420	
Potencia (Cv) a 1000 r.p.m. Power (HP) 1000 r.p.m		42 C.V // 32 Kw	
Lado de montaje Mounting position		Posterior Rear	
Sentido de giro de la bomba Pump rotation		Derecho Right Hand	
Peso Weight (Kg)		11,5	
Relación motor - Toma de Fuerza Engine to PTO ratio	R1000, R1400, R1700	1: 0,924	
	SR1400, SR1700, SR1900, VT2014B, VT2214B, VT2514B, DT-2412C	Larga High	1: 1,162
		Normal Normal	1: 0,924
	SR2000	Larga High	1: 1,082
		Normal Normal	1: 0,858
	SRO2400	Larga High	1: 1,360
		Normal Normal	1: 1,082
	VT1708, VT2009B		1: 0,924
	V2412AT, V2512AT, V2812AT, VT2412B	Larga High	1: 1,191
		Normal Normal	1: 0,924
	VO2512AT, VO3112AT	Larga High	1: 1,518
		Normal Normal	1: 1,188
VTO2214B, VTO2514B	Larga High	1: 1,443	
	Normal Normal	1: 1,162	

Códigos y Combinaciones Codes and Combinations

Kit toma de fuerza base con brida Base PTO Kit with flange		+	Kit de eje adaptador Adapter shaft kit	
			R1000, SR1700, ... (L=267mm)	110104
Salida Plato Flange output	1198K02		R1000, ... Retarder (L=302mm)	110304
Salida Bomba Pump output (DIN 5462)	1198K03		DT-2412C, V2412 (L=229 mm)	116504

Toma de Fuerza Power Take Off's

código code

1198K03

DT-2412C, R1000, R1400, R1700, SR1400, SR1700,
SR1900, SR2000, SRO2400, VVO2512AT, V2812AT,
VO3112AT, VT1708, VT2009B, VT2014B, VT2214,
VT2412B, VT2514B

Volvo

Posterior Neumático (1: 1,32)

Rear Pneumatic

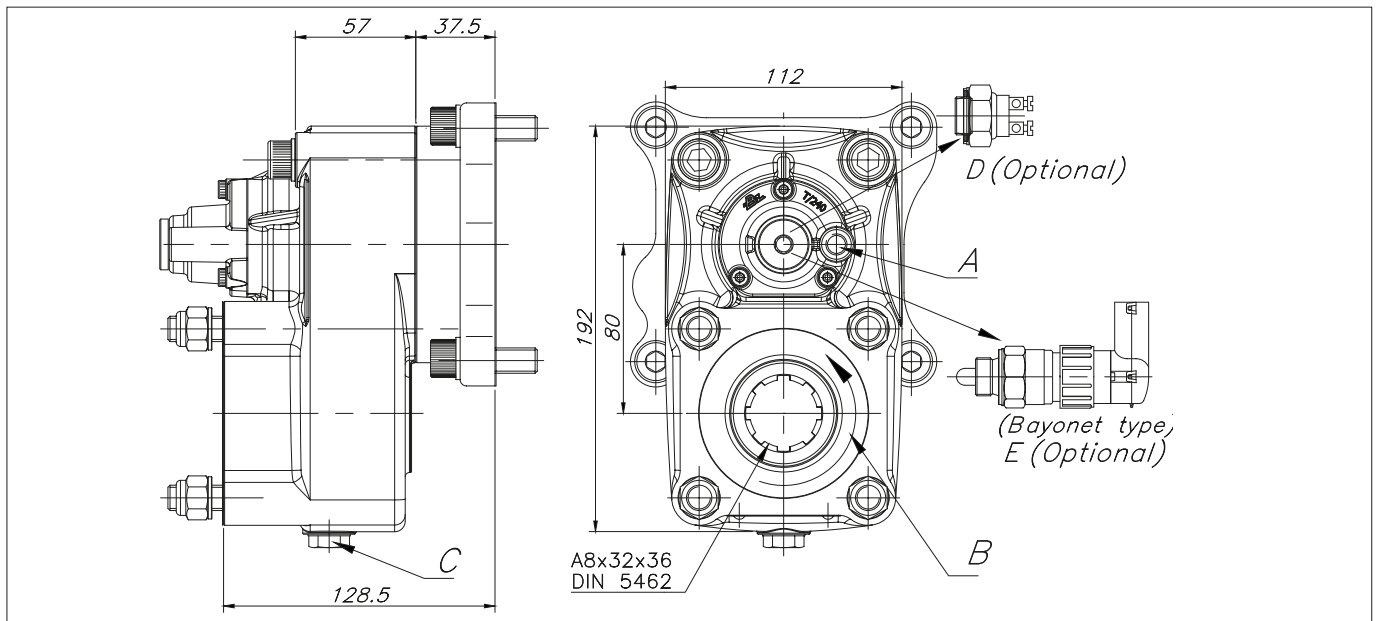

Notas Notes

A	Toma de aire, rosca 1/8" GAS	A	Air connection, thread 1/8" BSP
B	Sentido de giro	B	Rotation
C	Tapón de drenaje	C	Oil drain plug
D	Interruptor neumático. (100070018)	D	Pressure switch. P/N 100070018
E	Interruptor de contacto. (9024999)	E	Interruptor de contacto. P/N 9024999

Tipos de Salida Output Types

