

# Toma de Fuerza Power Take Off's

código code

1000 Series & 2000 Series

Lateral 6/8 tal. 2 Engranajes  
SAE Six/Eight Hole, Two Gear-Single Speed

Neumático

Pneumatic



## Descripción Description

Las series 1000 y 2000 han sido diseñadas para funcionar en la mayoría de las transmisiones existentes en el mercado. Se trata de unas tomas de fuerza muy duraderas con una amplia gama de engranajes de ataque, accionamientos, relaciones de velocidad y tipos de salida para satisfacer todas las aplicaciones del mercado.

The 1000 and 2000 Series PTO's has been engineered to work with most of the existing transmissions in the market. They are very durable PTO with a wide range of input gears, shifters, speed ratios and output types to meet all of the market applications.

### Datos Principales Main Data

Lado de montaje Mounting position	Derecho, Izquierdo Right, Left	Inferior Bottom
Peso (Salida ISO) Weight (ISO Output)	14 kg	16 kg
Series	1000, 1010	2000, 2010

Relación motor - Toma de Fuerza (Consultar libro de aplicaciones) Engine to PTO ratio (See application book)

RELACIÓN INTERNA INTERNAL RATIO	TRABAJO INTERMITENTE INTERMITTENT SERVICE		TRABAJO CONTINUO CONTINUOUS SERVICE	
	Par Torque (Nm)	Potencia Power (H.P // Kw) A At. 1000 r.p.m.	Par Torque (Nm)	Potencia Power (H.P // Kw) A At. 1000 r.p.m.
55%(B)	350	49 // 37	250	35 // 26
73%(C)	350	49 // 37	250	35 // 26
86%(E)	310	44 // 33	220	31 // 23
95% (J)	310	44 // 33	220	31 // 23
125% (O)	280	39 // 29	200	28 // 21
137% (R)	280	39 // 29	200	28 // 21
150% (S)	260	37 // 28	180	26 // 19
165% (T)	240	34 // 25	170	24 // 18

# Toma de Fuerza Power Take Off's

código code

1000 Series & 2000 Series

Lateral 6/8 tal. 2 Engranajes  
SAE Six/Eight Hole, Two Gear-Single Speed

Neumático  
Pneumatic

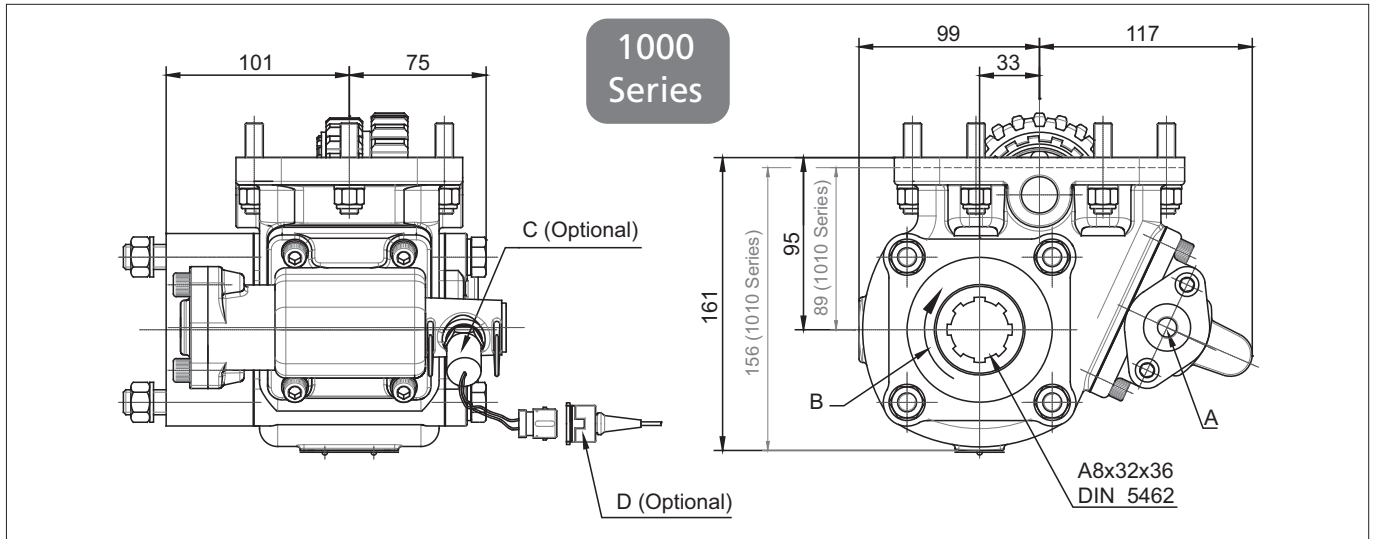

## Notas Notes

A	Toma de aire, 1/4" GAS	A	Air connection, thread 1/4" BSP
B	Sentido de giro	B	Rotation
C	Indicador de funcionamiento. (Opcional: 100070012)	C	Indicator switch P/N 100070012 (Optional)
D	Conector con 3m. de cable. (Opcional: 906599)	D	Connector with 3m. of cable. P/N 906599 (Optional)

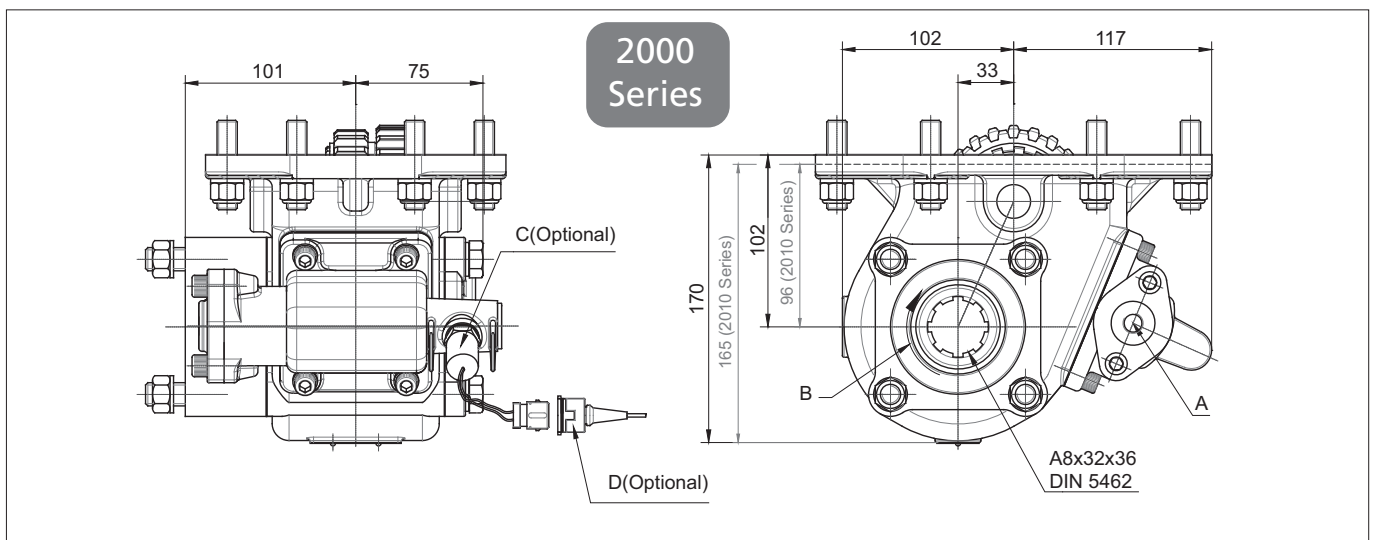

# Toma de Fuerza Power Take Off's

código code

1000 Series & 2000 Series

Lateral 6/8 tal. 2 Engranajes  
SAE Six/Eight Hole, Two Gear-Single Speed

Neumático  
Pneumatic

## Tipos de Salida Mas Usadas Most Standard Output Types

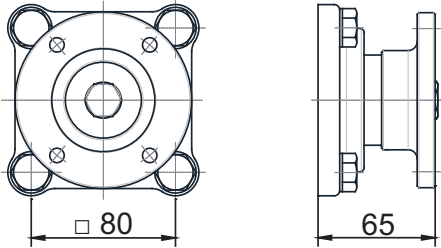
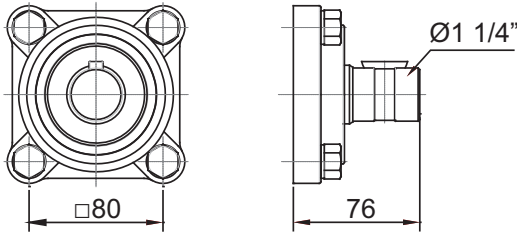
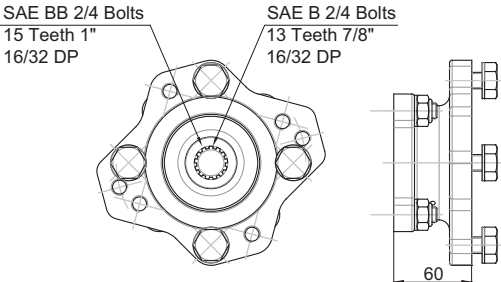
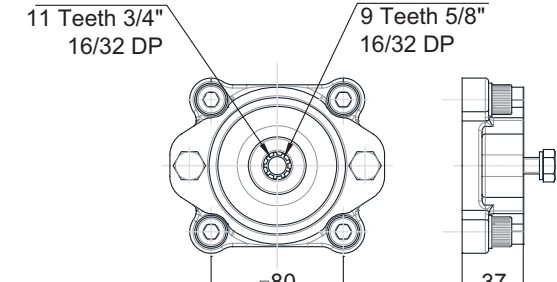
Plato Flange	Eje Chaveteado Round Shaft
<p>SAE: 1100 1300 1400</p> <p>DIN: 90 100</p> 	
SAE "B" 2/4 Taladros SAE "B" 2/4 Bolts	SAE "A" 2 taladros SAE "A" 2 bolts
 <p>SAE BB 2/4 Bolts 15 Teeth 1" 16/32 DP</p> <p>SAE B 2/4 Bolts 13 Teeth 7/8" 16/32 DP</p>	 <p>SAE AA 2 Bolts 11 Teeth 3/4" 16/32 DP</p> <p>SAE A 2 Bolts 9 Teeth 5/8" 16/32 DP</p>

## Accionamiento Mecánico Mechanic Shifting

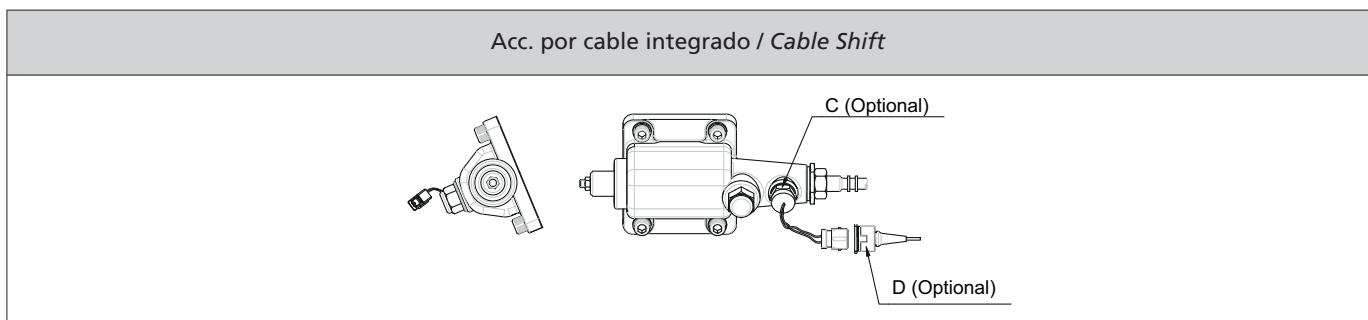

# Toma de Fuerza Power Take Off's

código code

1000 Series & 2000 Series

Lateral 6/8 tal. 2 Engranajes

SAE Six/Eight Hole, Two Gear-Single Speed

Neumático

Pneumatic

## CODIFICACIÓN PTO PTO CODING

