

280203

YAMZ 239.

**MAZ**

## Posterior Neumatico (1:1.32) Rear Pneumatic

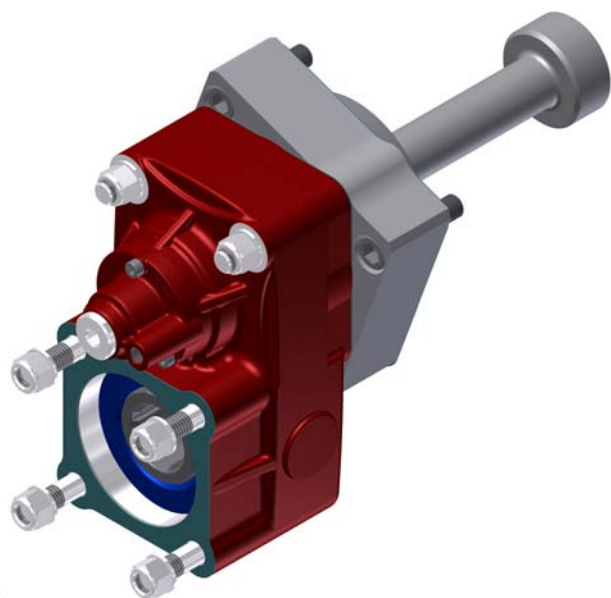

## Descripción Description

Toma de fuerza de dos piñones con relación interna de 1:1.32 para montar en el registro frontal de 4 taladros de la caja de cambios. Accionamiento neumático, para montar bombas ISO 4 taladros. Indicador de funcionamiento opcional.

Power Take-off two gears, with an internal ratio of 1:1.32 mounting on rear 4bolts-window of the Gearbox. Pneumatic shifting, to connect ISO 4 bolts pumps. Optional: Passing contact switch.

## Datos Principales Main Data

Par nominal Torque (Nm)	Continuo Continuous	300
	Intermitente Intermittent	420
Potencia (Cv) a 1000 r.p.m. Power (HP) 1000 r.p.m.	42 C.V. // 32 Kw	
Lado de montaje Mounting position	Posterior Rear	
Sentido de giro de la bomba Pump rotation	Derecho Right Hand	
Peso Weight (Kg)	14.3	
Relación motor – Toma de Fuerza Engine to PTO ratio		

280203

YAMZ 239.

**MAZ**

Posterior Neumatico (1:1.32)  
Rear Pneumatic

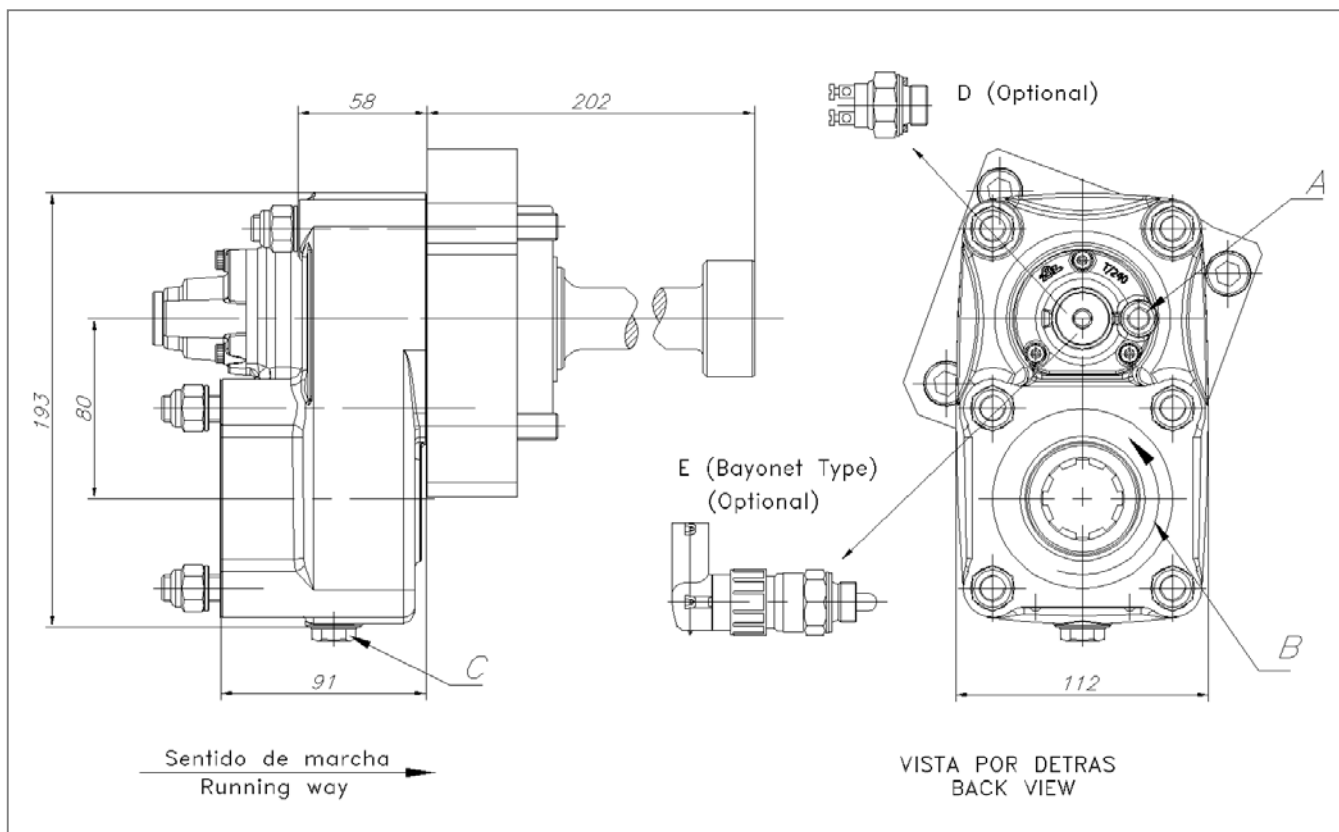

Notas Notes

A	Toma de aire, rosca 1/8" GAS	A	Air connection, thread 1/8" BSP
B	Sentido de giro	B	Rotation
C	Tapón de drenaje del aceite.	C	Oil drain plug.
D	Interruptor neumático (100070018)	D	Pressure switch P/N 100070018
E	Interruptor de contacto (9024999)	E	Passing contact switch. P/N 9024999