

BE LS 60/80/100



Descripción Description

Bombas de engranajes con cuerpo reforzado, puertos laterales y traseros. Doble rodamiento cónico de apoyo para el eje.

Gear pumps with heavy duty body, side and rear ports. Double support by taper roller bearings on the shaft.

Datos Principales Main Data

		BE LS 60	BE LS 80	BE LS 100
Tipo de Bomba Pump Type		BE LS 60	BE LS 80	BE LS 100
Codigo Part Number		5047606	5047706	5047806
Desplazamiento Displacement (cm ³ /rev)		60	80	100
Presión máxima continua Maximum continuous pressure (P1) (bar)		270	230	210
Presión máxima pico Maximum peak pressure (P3) (bar)		310	270	240
Velocidad Speed (r.p.m)	min. (P1)	500		
	máx. (P1)	1800	1600	1400
Dimensiones Dimensions (mm)	A	206	218	224
	B	132	146	153
Peso Weight (Kg)		14.1	15.2	16.4

Dirección de Rotación Rotation direction

Reversible, con drenaje interno
Bi-directional, internal drain

Presión de Entrada Input Pressure	Recomendado Recommended	0.7÷ 3 bar (abs)
Temperaturas Temperatures		Desde -25°C a +80°C From -25°C to +80°C
Viscosidad Viscosity	Recomendado Recommended	De 12 a 100 mm ² /s (cST)
	Permitido Allowed	Hasta 750 mm ² /s (cST)

BE LS 60/80/100

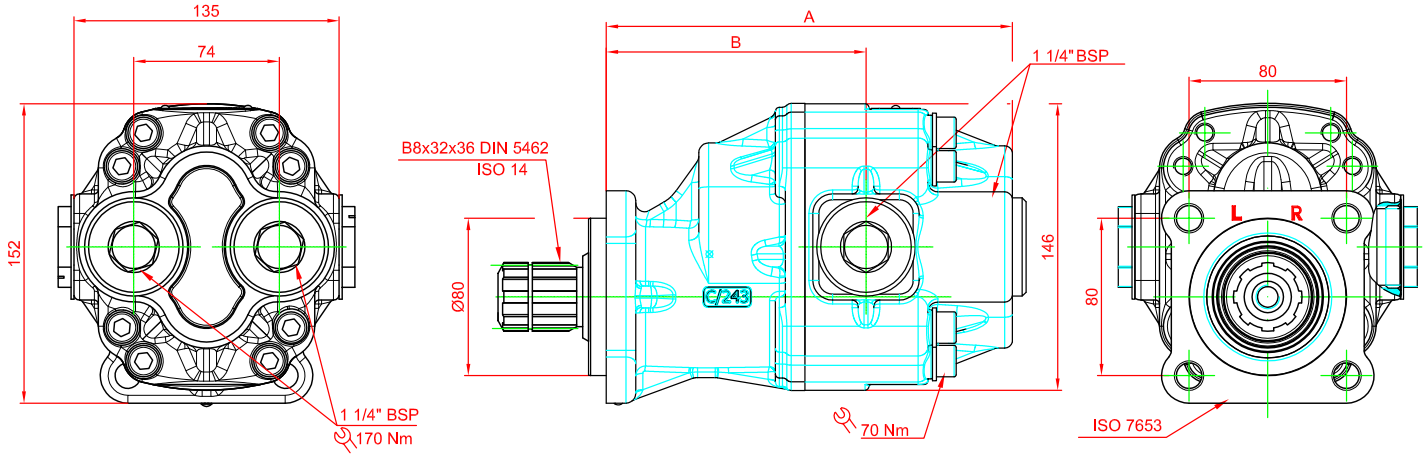

Curvas de Rendimiento Performance Curves

